

Blu2Light



Operating Manual LiNA Connect / LiNA

LiNA
Connect

Programming the Blu2Light System

Using LiNA Connect

LiNA
Touch

Operating the Blu2Light System

Using LiNA Touch

TABLE OF CONTENTS

1	General Notes.....	4
1.1	Legal notice.....	4
1.2	Downloading the APP.....	4
1.3	Version note.....	5
2	Preparation	6
3	How to create a simple system	6
4	Backup/Restore of a system.....	17
4.1	Backup.....	17
4.2	Restore	19
4.2.1	Normal Restore/Import of a backup file.....	19
4.2.2	Full Restore	21
5	Copy device configuration	21
6	Using Auto mode	30
7	Setting up the tunable white function.....	31
8	Implementing a DigiLED (186839) + manual configuration	33
9	Daylight control explained	36
10	Light-Threshold-Function explained.....	38
11	How to use motion detection	41
12	Using Sequences	43
12.1	Event configuration of sequences.....	46
12.2	Retrigger a sequence	46
13	Add and use Timers	47
14	Using the Air Sensor	51
15	Using the Blu2Light Relais.....	53
16	Using the B2L Connect PB4	59
17	Including an Blu2Light Repeater.....	62
18	Including the Blu2Light Connect DMX Controller.....	63
18.1	Receiver Mode.....	63
18.2	Master Mode	66
18.3	Using Receiver and Master Mode in combination.....	69
18.4	Master Follower Mode	71
19	Automatic addressing after replacing a DALI driver	74

20	Do's and don'ts.....	75
20.1	Do's	75
20.2	Don'ts	76
20.3	Informal	76
20.3.1	Description of Symbols	77

1 GENERAL NOTES

Thank you for choosing the Vossloh-Schwabe Blu2Light system. Prior to using the product, please read this operating manual to familiarize yourself with the system's functions.

Any person tasked with system setup, commissioning, operation, maintenance, and repair must be:

- suitably qualified and
- closely observe the provisions of this operating manual.

1.1 Legal notice

Trademarks

- The Vossloh-Schwabe and the Blu2Light logos are trademarks of Vossloh-Schwabe Deutschland GmbH.
- Other products and company names mentioned in this manual may be trademarks of other companies.

Copyright

© Copyright 2022 by Vossloh-Schwabe. All rights reserved. Without the prior written consent of Vossloh-Schwabe, no part of this document may be reproduced or transmitted in any form or using any means, be they electronic or mechanical; nor may photocopies or any other kind of record be made, nor may any system for information storage or restoration purposes be used.

1.2 DOWNLOADING THE APP

Both apps are available as iOS and Android versions in the respective app stores.

	LINA Touch	LINA Connect
		
		

1.3 VERSION NOTE

Change log	
Document	Changes
1.0	<ul style="list-style-type: none"> - Document created in English language. - Blu2Light Connect DMX Controller added.
2.0	<ul style="list-style-type: none"> - Blu2Light Relay – Function description revised.
2.1	<ul style="list-style-type: none"> - Version assignment and change log added. - Creation of sequences – Added reference to Auto Mode.
2.2	<ul style="list-style-type: none"> - Create backup/restore of a system. - Description of symbols added. - Threshold function added.
2.3	<ul style="list-style-type: none"> - Blu2Light Relay – Function description revised. - Retrigger a sequence - Restart the Bluetooth mesh in the network overview. - Replace a defective Blu2Light device. - Exchange the system key.
2.4	<ul style="list-style-type: none"> - Re-addressing after DALI driver change

2 PREPARATION

Make sure that all your Blu2Light nodes are powered and that the QR codes of the nodes are ready, for example stuck on your floor plan!

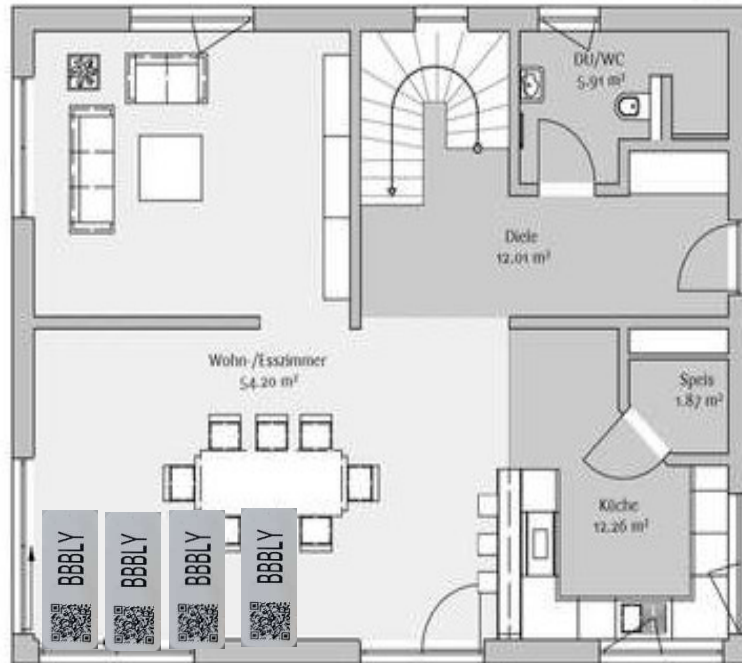



Figure 1: Floor plan

3 HOW TO CREATE A SIMPLE SYSTEM

Open the LiNA Connect app and click on the button  in the lower right corner to create a project, then name your project and create a system with the same procedure. Now scan the desired QR code by pressing the button  again!

The following picture shows a successful scanning of a Blu2Light device in LiNA Connect – the QR-Code is shown in green color:

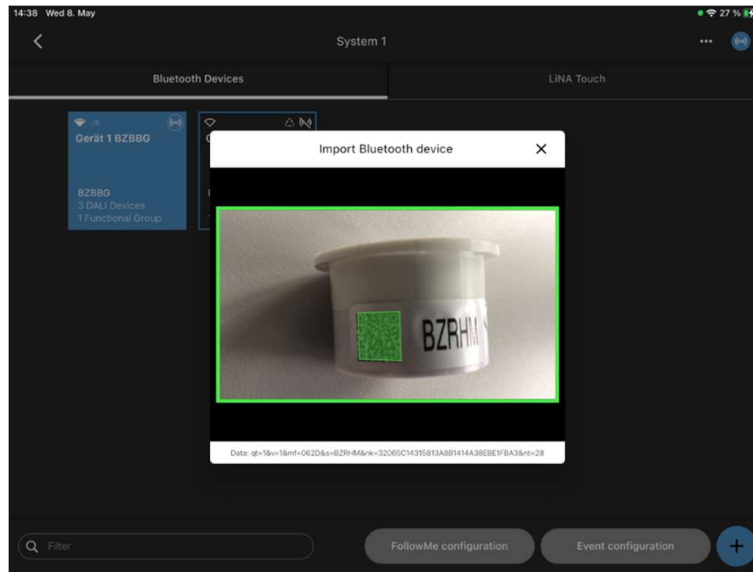

Figure 2: Scanning a Blu2Light device

If you have multiple devices to scan, you can use continuous import.

Scanning of 2 Blu2Light device which has already been commissioned to another system on the tablet – the QR-Code is shown in orange color:

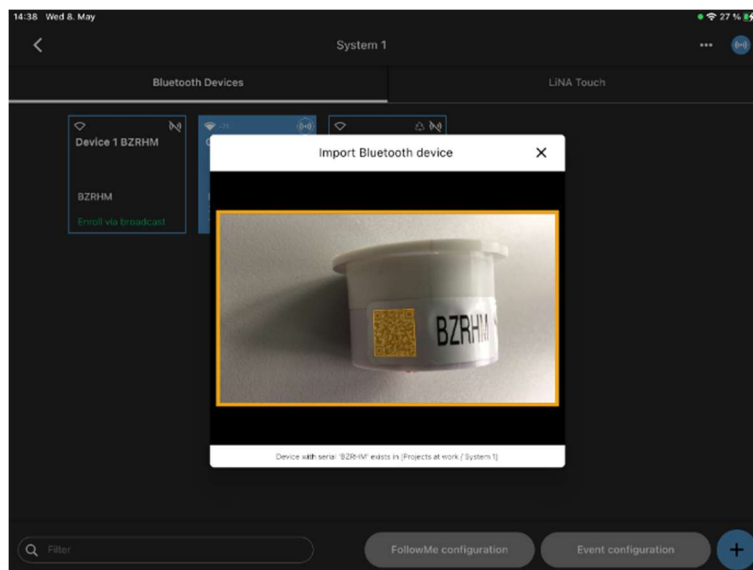

Figure 3: Scanning a Blu2Light device that is already in use

The text field below the scanned node shows you where it is already in use.

Color selection of a Blu2Light device in the device settings:

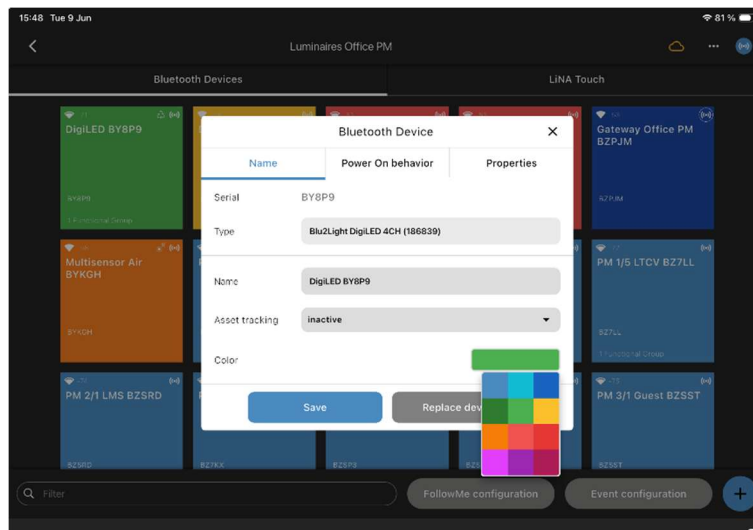

Figure 4: Color selection

A long press on the device icon displays the device overview. There you will find the options "Name," "Power On Behavior," and "Properties." The "Power On Behavior" option is not displayed for all Blu2Light devices, but only for those that support this function (e.g., not for the Blu2Light LAN Gateway or the Blu2Light Connect PB4). Furthermore, you can select the desired color for each node, which will be used to display it in the respective system. This improves clarity in large projects and thus offers better visualization.

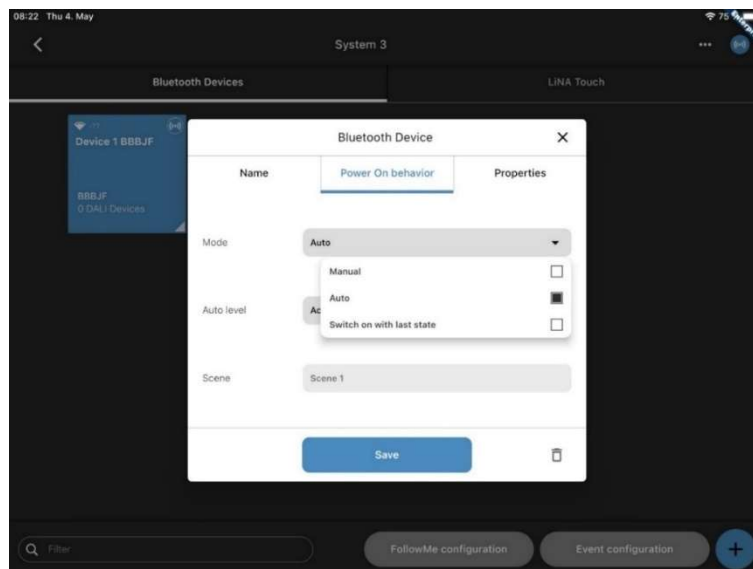

Figure 5: Selection of switch-on behavior

Select "Switch on with last state" in the "Power On Behavior" tab.

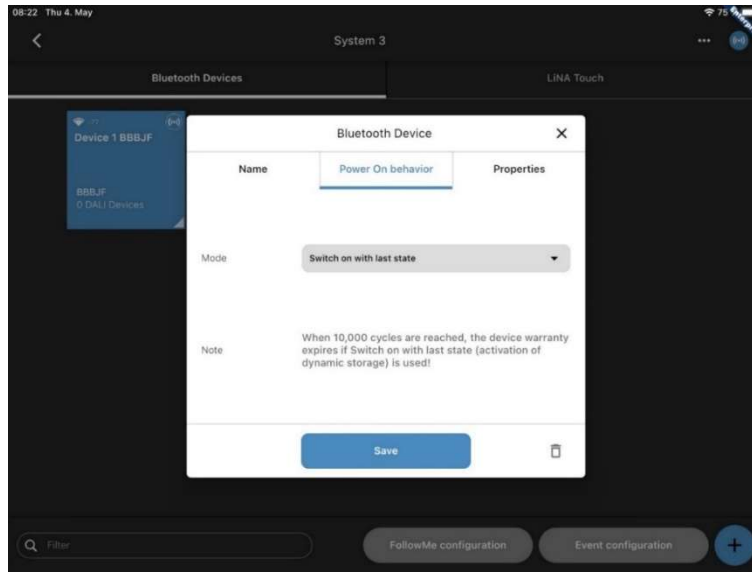

Figure 6: Switch on with last state

Now the node uses the "last state" as "Power On behavior". Please be aware not to cut off the power for at least 30 seconds before a new "power on last state" is being saved after this mode has been configured. A counter in the "properties" shows the actual state of how many configuration changes have been done in a lifetime of the node. Only configuration changes that last longer than 30 seconds are being saved. If a counter-state of 10 000 has been reached the VS guarantee is lost. The function remains available.

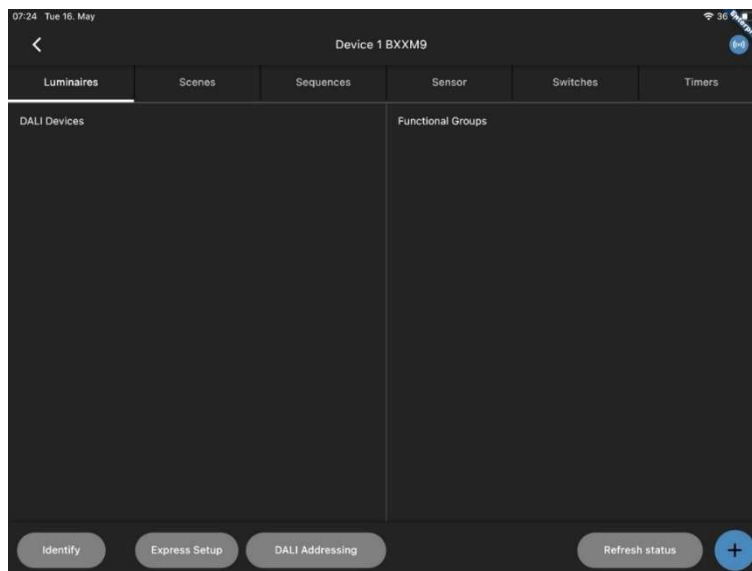

Figure 7: Overview before automatic setup

Select a node and select "Express Setup" to start automatic setup.

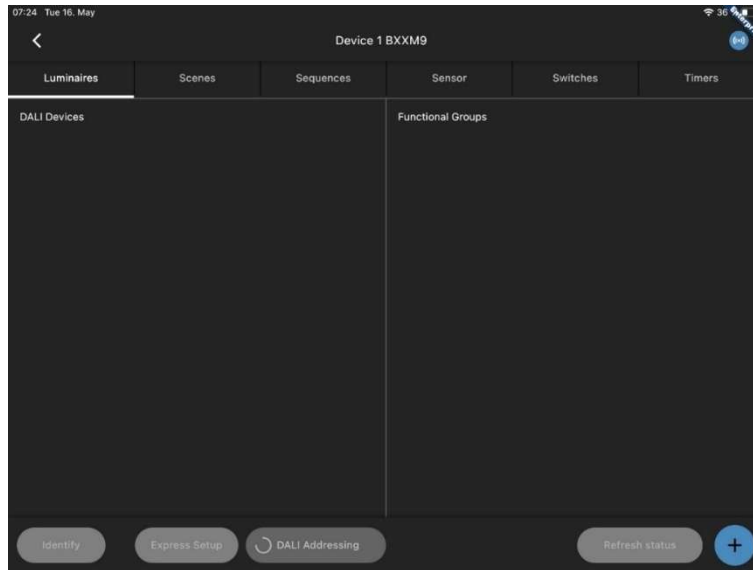

Figure 8: Express setup with active DALI search

A rotating circle at "DALI addressing" indicates an active DALI search.

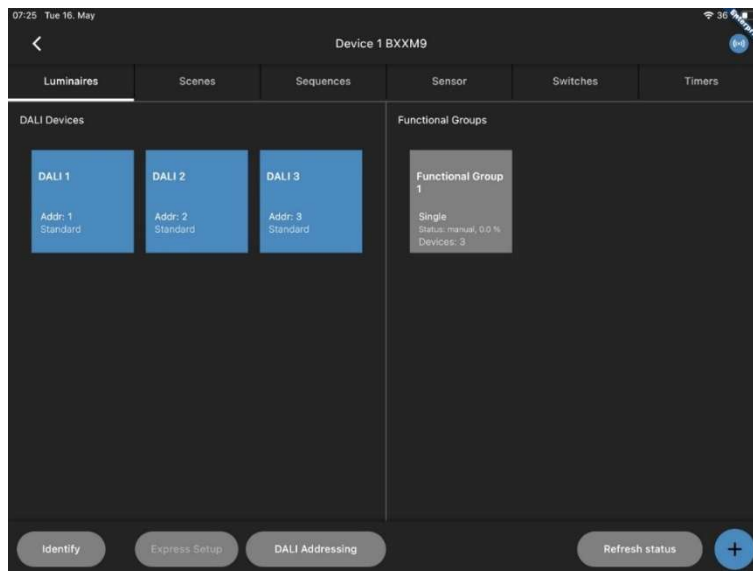

Figure 9: Overview after successful DALI search

If the DALI search is completed, all DALI devices should be displayed, and a functional group should have been created.

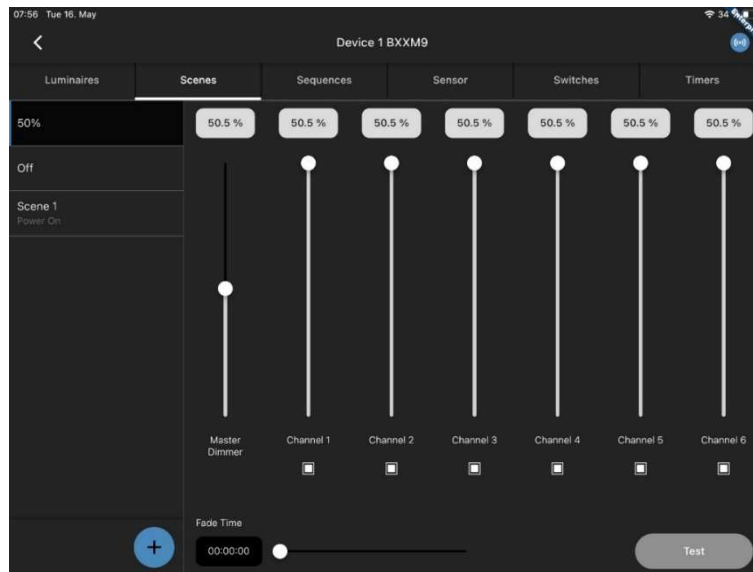



Figure 10: Menu for creating scenes

Now you can create scenes according to your wishes, "50 %", "Off" and "On" are the most common ones. Now add a new scene by pressing the button  !

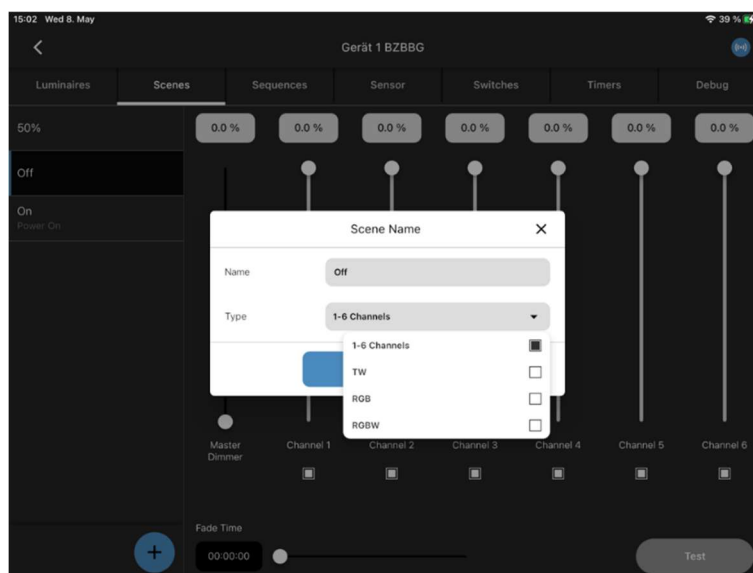

Figure 11: Creating a new scene

Here you can name the scene as you wish and select the type of luminaire module used. A maximum of 64 scenes can be created!

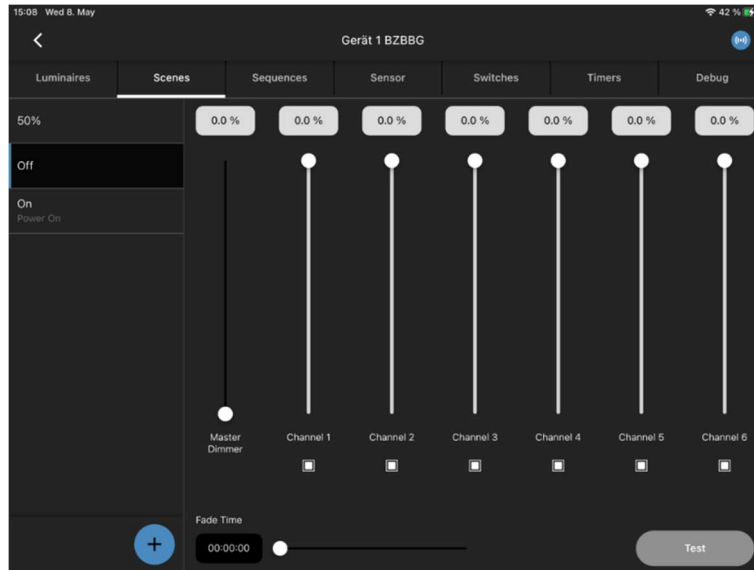

Figure 12: Created "Off" scene

In most configurations, it is recommended to leave at least one channel switched on. The slider for the master dimmer should be set to zero for the "Off" scene.

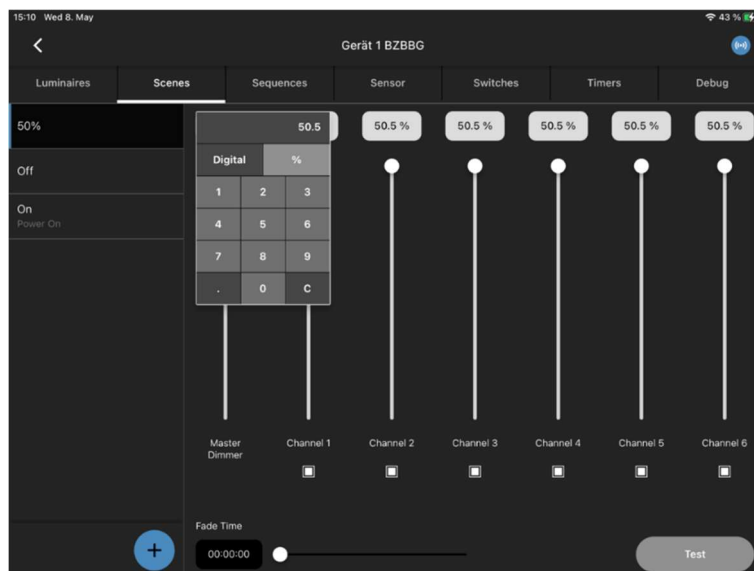

Figure 13: Setting the brightness level

The brightness can be set using the slider or by pressing the brightness value displayed above (allows digital or percentage values to be entered).

If all scenes are configured as desired, the only thing left is to generate a user interface in the LiNA Touch App, for that, switch to the tab "LiNA Touch".

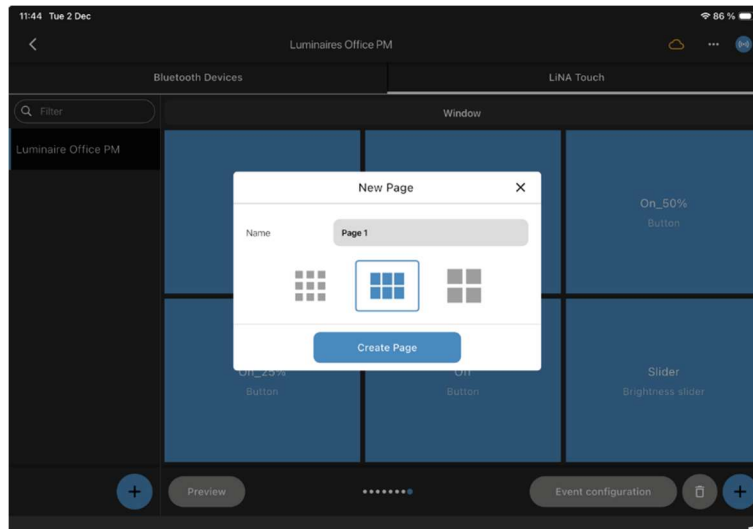



Figure 14: Creating a LiNA Touch user interface

Here you can use the  button on the left-hand side to create a new touch profile and name it accordingly. Use the  button on the right-hand side to select a touch surface, depending on the scope of the desired functions. Unused touch panels will not be displayed in the LiNA Touch app. If more touch panels are needed more fields can always be added.

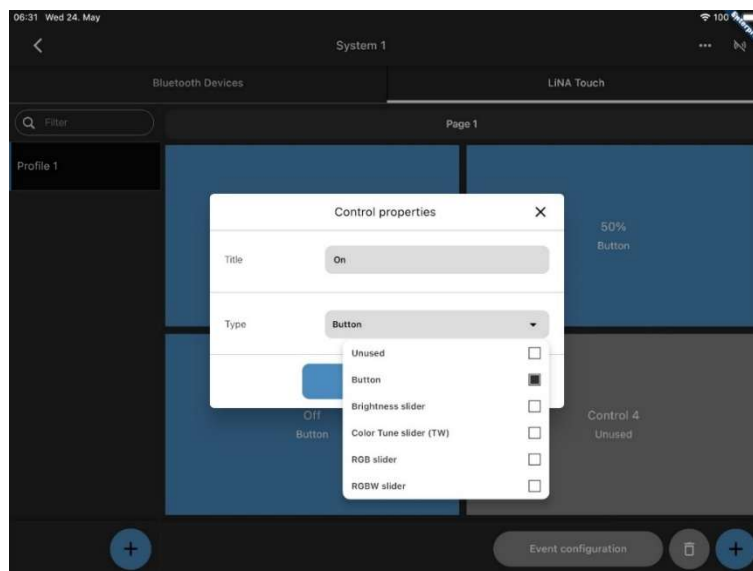

Figure 15: Assigning a function

Each control panel must now be assigned a function that can later be used in the Touch App. It is advisable to name the control surface according to the scene to be controlled.

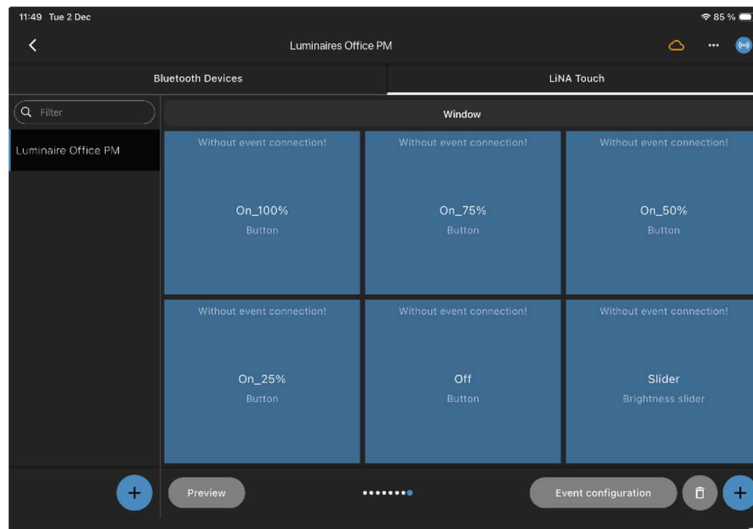

Figure 16: LiNA Touch user interface created

Once this is achieved, your user interface should look like this. At the top of a control panel with an assigned function, a message will appear indicating that no event link has yet been created.

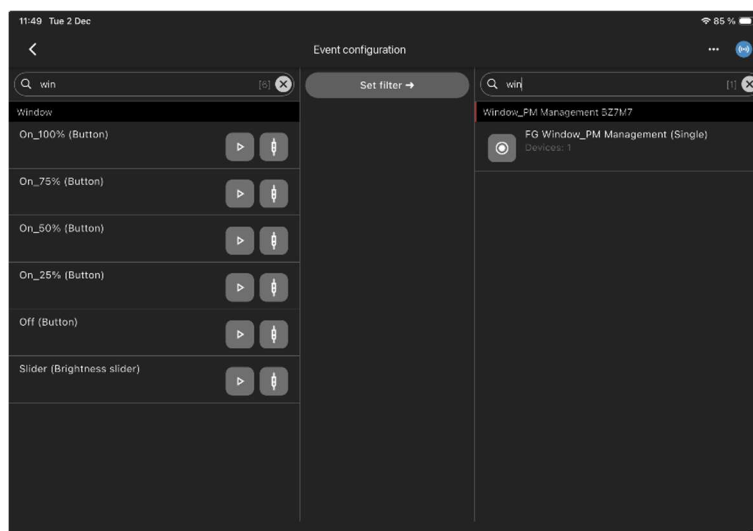

Figure 17: Event configuration

Now the control panels are assigned to the respective functional groups and (Figure 18) to the respective scenes via the event configuration using drag & drop.

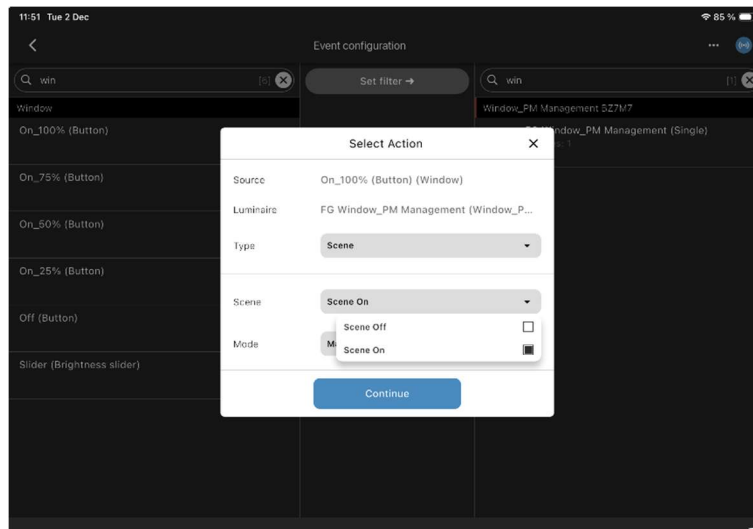

Figure 18: Assignment of the scenes

Select the correct scene using the button. You can also choose whether the desired scene should be started in manual or automatic mode. Automatic mode must be selected if motion and/or light control is desired when the scene is activated.

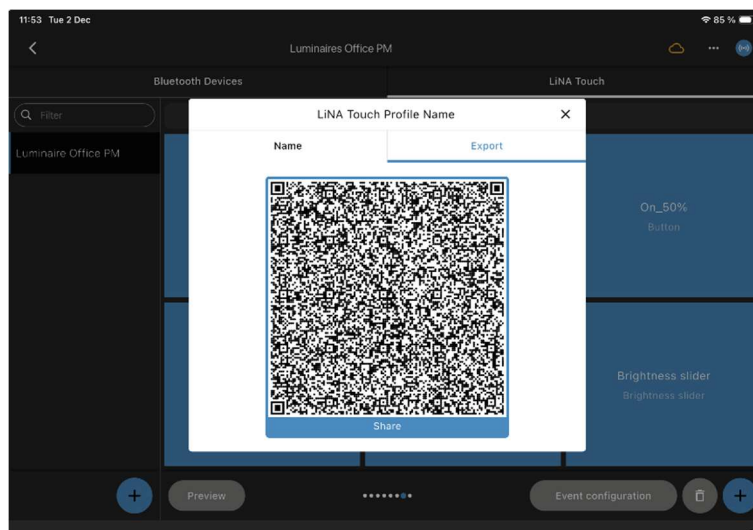

Figure 19: Export the desired LiNA Touch profile

In the last step, press and hold the respective touch profile you want to export in the main window of the Connect app and select "Export". Now you are free to scan the generated QR code with another device using the LiNA Touch app or to export it in another way by pressing "Share".

To scan the QR code, press the QR code symbol in the upper right corner of the LiNA Touch App and scan the respective QR code.

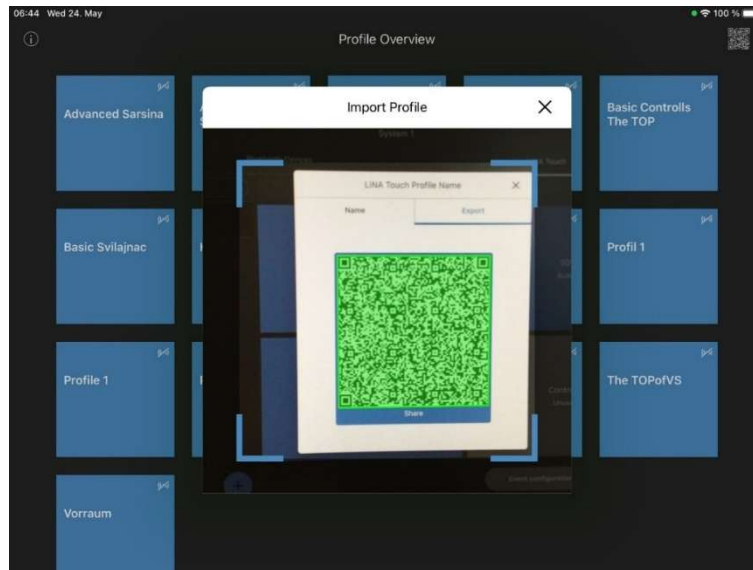

Figure 20: Scanning the profile to be imported

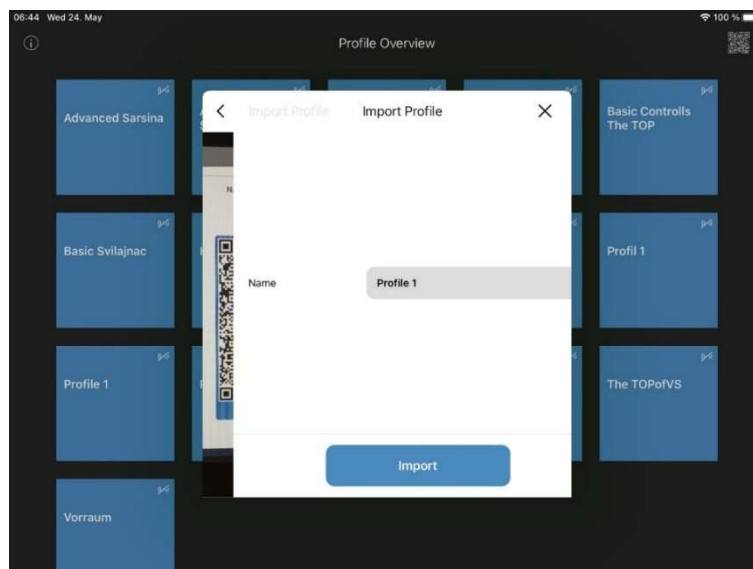

Figure 21: Importing the profile

Congratulations!

Your basic system is now fully operational and can be operated via the LiNA Touch App!

4 BACKUP/RESTORE OF A SYSTEM

To avoid data loss, it is generally recommended that you make regular backups of your data.

4.1 BACKUP

A Blu2Light system backup prevents loss of access to the system. As already mentioned, the best time to create a backup is after a system has been successfully commissioned.

Standard functions of the operating system of mobile devices (such as iCloud) can be used to securely store a backup file.

Besides data backup in case of a damaged mobile device, backups have a second purpose: transferring the system from one mobile device to another.

In both cases, it is important that only one device is connected to the system and that the backup is transferred back to the other device after a change has been made to the system.

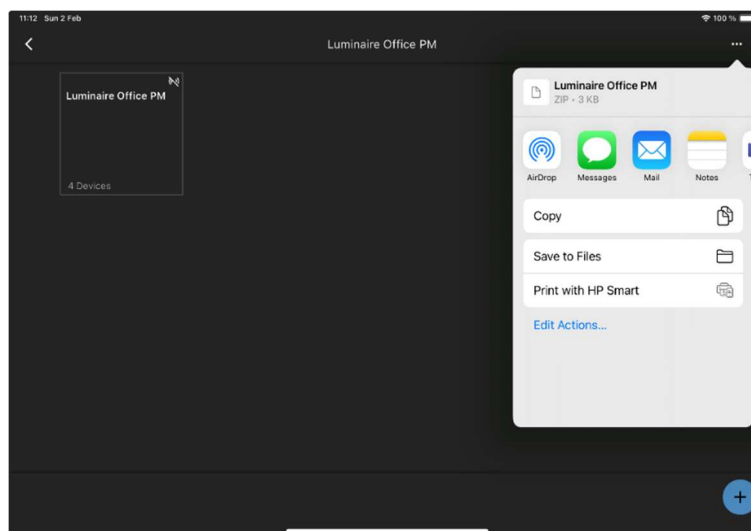

Figure 22: Backup as zip file

It is recommended to select 'Save to Files'. You can then save the backup file in the cloud or on the tablet. The file name contains the name of the project and the current date and time stamp.

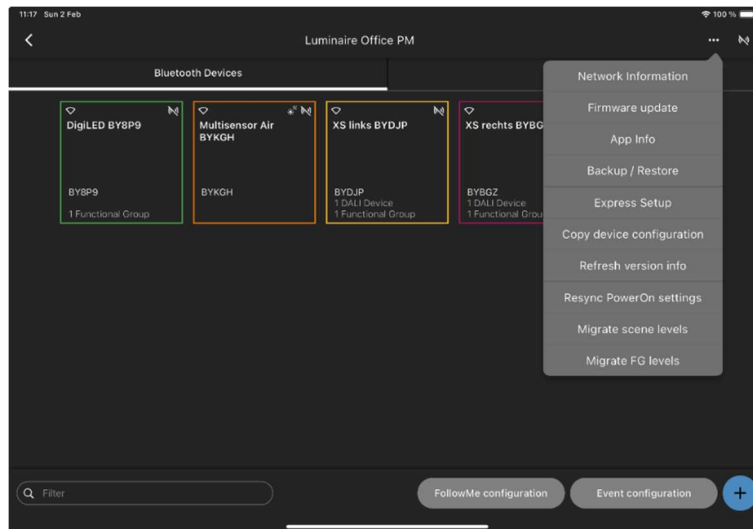
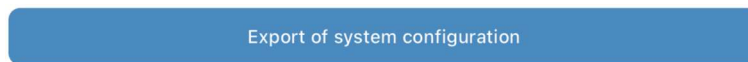
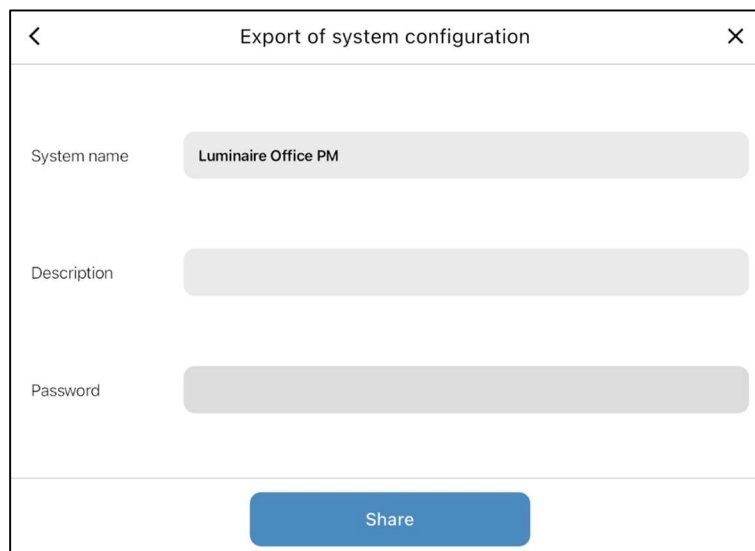

Figure 23: Backup of a system configuration

Select 'Backup / Restore', then 'Create new backup / Export current configuration' and then 'Export of system configuration'.



In the following window, the system configuration to be exported can be described and protected with a password.



The 'Export of system configuration' dialog box contains the following fields:

- System name:** Luminaire Office PM
- Description:** (empty text field)
- Password:** (empty text field)

A blue 'Share' button is located at the bottom of the dialog.

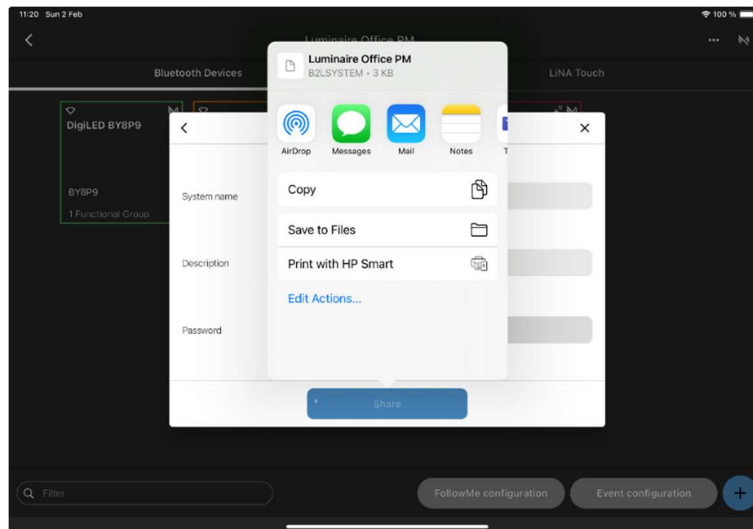

Figure 24: Backup of system configuration

It is recommended that you select 'Save to Files'. You can then save the backup file in the cloud or on the tablet. The file name contains the name of the system and the current date and time stamp.

WARNING: Accessing a Blu2Light system with two mobile devices (simultaneously or alternately) leads to uncorrectable data corruption and may require a complete restart of the system. If two mobile devices are accidentally used and the system does not behave as intended, a restore - full restore - may help.

4.2 RESTORE

An existing backup can be restored in various ways:

4.2.1 NORMAL RESTORE/IMPORT OF A BACKUP FILE

A 'normal' restore loads a configuration from an existing backup into the LiNA Connect app. This can be used to transfer a system from one mobile device to another. In this case, it is recommended to delete the system on the old device to prevent accidental access to the same system from multiple devices.

It is recommended to always save a backup file on the tablet or in the cloud before importing it into the app. A zip file is automatically unpacked into the corresponding B2L system file after selection. Select the system configuration to be imported in your own files or in the cloud. Share this with the LiNA Connect app.

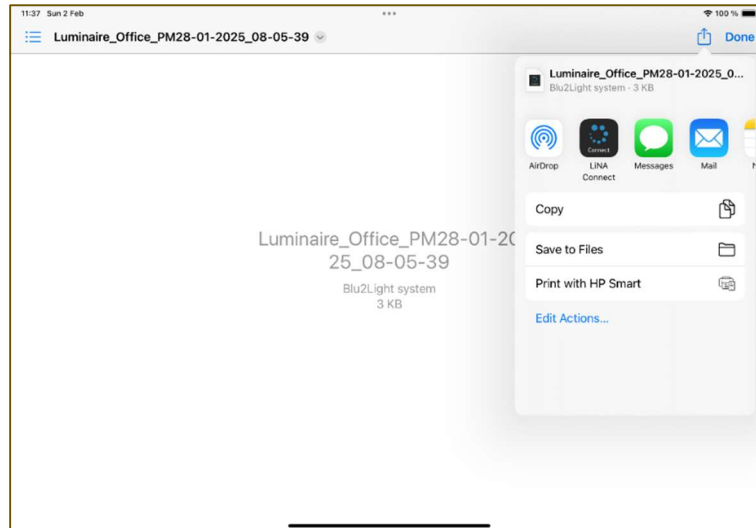

Figure 25: Sending the system configuration to the LiNA Connect App

If the system already exists, this is recognized by the LiNA Connect app and the corresponding project is selected. If it is a new system, the project into which the system is to be imported must first be selected.

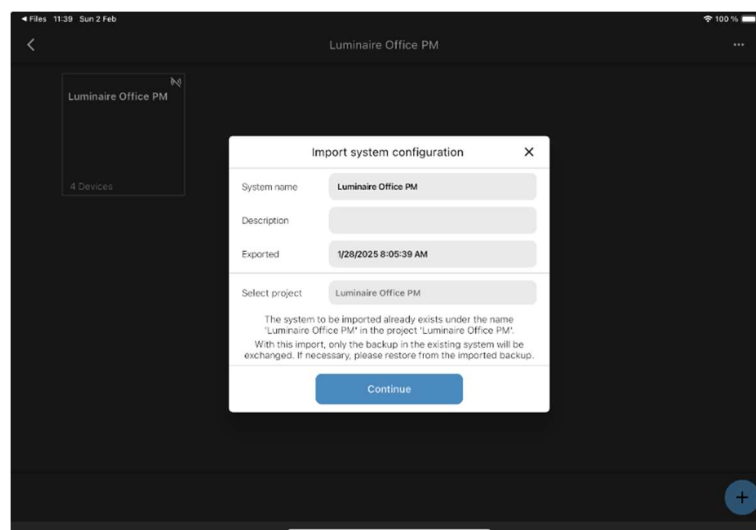

Figure 26: Importing the system configuration

System configuration was successfully imported.

Please remember to delete this system on other tablets.
Configuration access from multiple tablets is not allowed!

Ok

A window informs you when the system configuration has been successfully imported.

NOTE: There is no synchronization with the nodes.

WARNING: If an old configuration is loaded and there is a wireless connection to the system, changing parameters can lead to unpredictable behavior.

4.2.2 FULL RESTORE

During a full restore, the backup is loaded onto the mobile device in the LiNA Connect app. Then the nodes are (re)commissioned and finally each node is programmed with the required configuration. This ensures consistency between the application and all nodes in a system.

Full restore incl. overwrite of device configuration

NOTE: During a full restore, it will take some time for all actions to be completed. During this time, the connection to the mesh nodes must not be interrupted. An existing daylight control system must be stopped and restarted.

5 COPY DEVICE CONFIGURATION

Within LiNA Connect, it is possible to speed up the setup process of one or more nodes by using the “Copy device configuration” option. With this option, it is possible to copy the settings of a node that has already been configured with LiNA Connect to one or more other nodes that are integrated in the same system. This option is useful, for example, if equivalent scenes are required on several nodes within the same system. The “Copy device configuration” option can be found in the open system in the menu in the top right-hand corner by clicking on the “3 dots”.

The following illustration shows the “Menu” and the “Express Setup” option in the LiNA Connect menu.



Figure 27: “Copy device configuration”-Option in the Menu of LiNA Connect App

It is important to know that not all functions of a Blu2Light node are copied. Only the following options are copied:

- Scenes,
- sequences,
- Motion settings,
- Brightness settings (there is no active light control on the target node, even if one is running on the "source" node),
- timers,
- LiNA Touch event configuration shortcuts.

The next window shows all the nodes present in the system. The "source" node with all the settings to be copied from must now be selected from the existing nodes in the system:

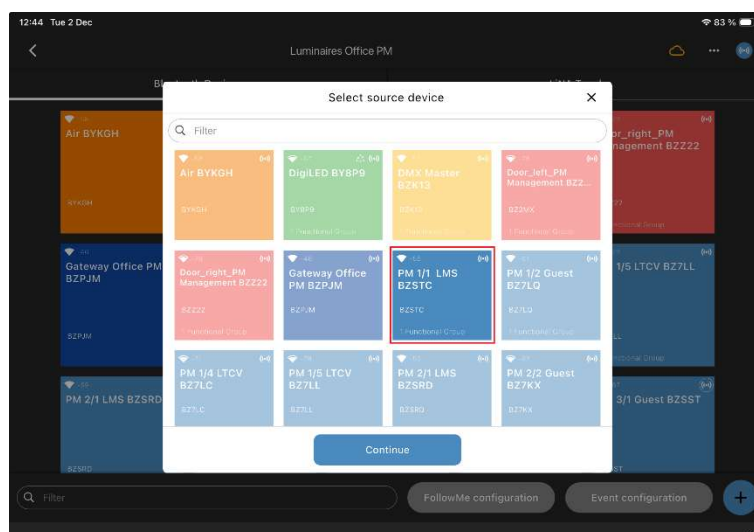

Figure 28: Selection of the "source device", indicated by the red frame

In the next step, the destination node(s) is/are selected after you have clicked on "Continue":

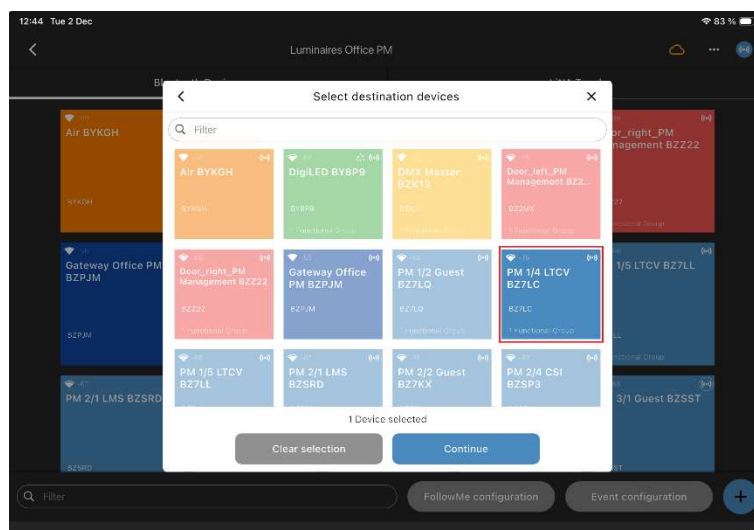

Figure 29: Selection of the "destination device", indicated by the red frame

When the selection of the destination node (one or more nodes) has been successfully completed, a further options menu appears in which you can decide whether LiNA Connect should wait until a device is “online” and whether some possible profile options in LiNA Touch should also be updated with the current copy process:

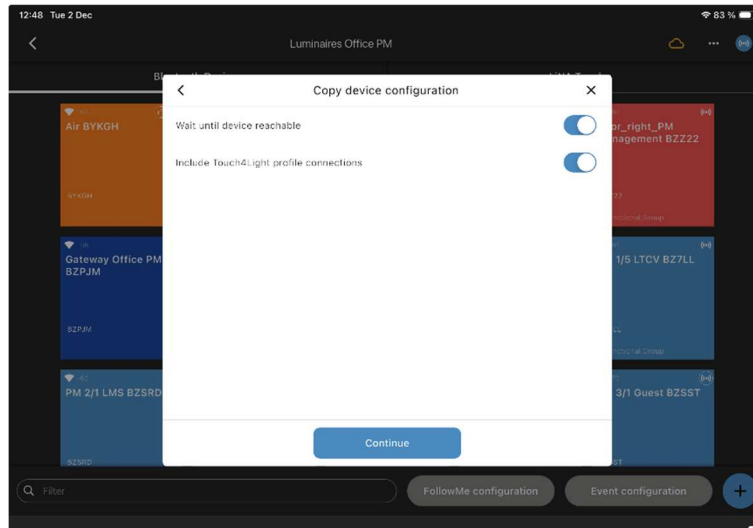

Figure 30: Options menu with additional options for the copy process

In most cases, it is advisable to leave both actions activated, as any LiNA Touch connections should be updated. It also makes sense to wait until a node is available and online or in range before starting the copy process.

The following illustration shows a successful copy of the settings from one node to another:

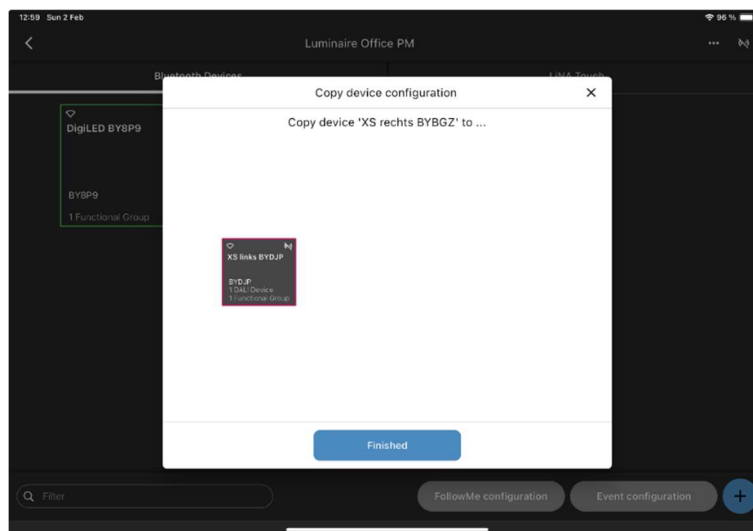

Figure 31: Successful copying of settings from one node to another node

After clicking on “Finished”, the copied options can be used on the target node.

6 REPLACING A DEFECTIVE BLU2LIGHT DEVICE

This function allows you to replace a defective device with one of the same types. The configuration is retained. For the assistant to work, the device being replaced must be completely unreachable. Devices that can respond will not be replaced.



Figure 32: Menu for replacing a Blu2Light device

Follow the wizard that will guide you through replacing defective hardware.

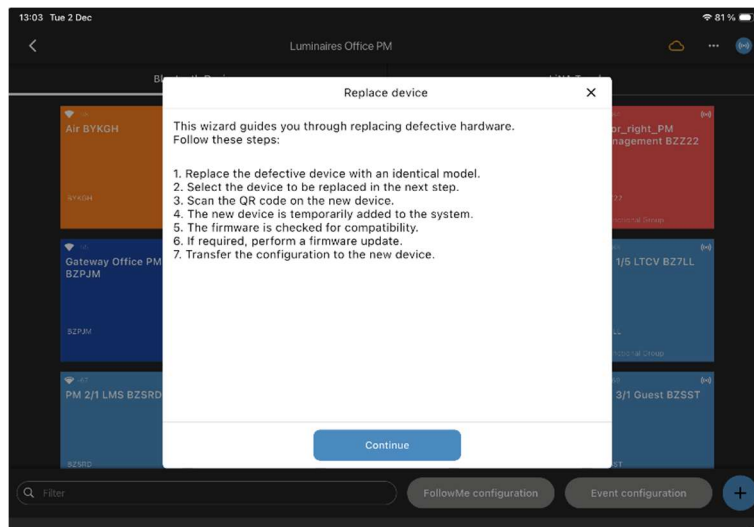

Figure 33: Assistant for replacing defective hardware

Select the device to be replaced.

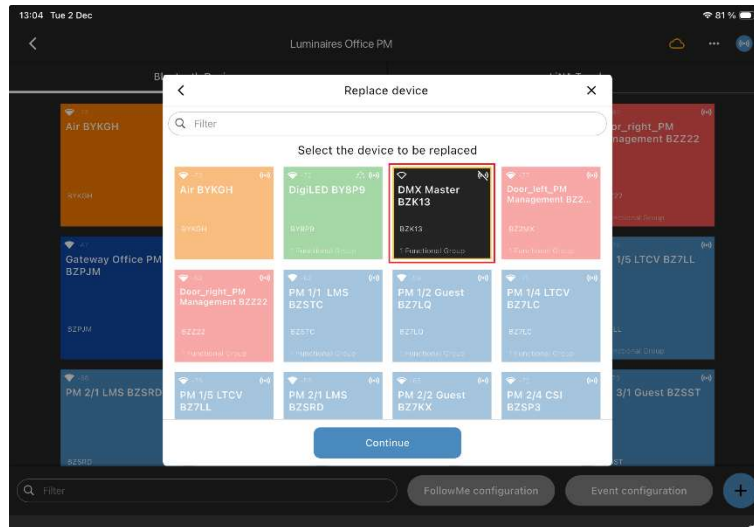

Figure 34: Selecting the device to be replaced

The dialog box for scanning the QR code of the new device will then open. It will be temporarily added to the existing system. After checking the firmware, an update may be necessary. The settings from the old device will then be transferred to the new one.

7 CHANGE OF THE SYSTEM KEY

This function allows the user to provide a new system key to a registered system.



Figure 35: Menu for replacing a Blu2Light device

Follow the wizard that will guide you through replacing the system key.

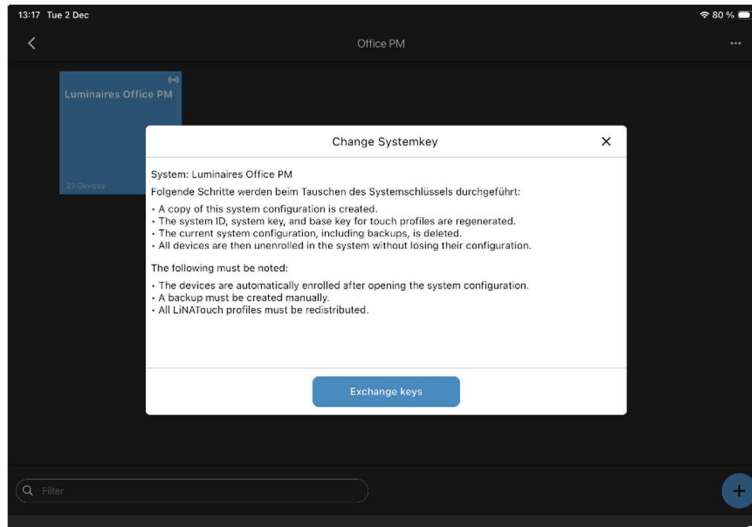

Figure 36: Assistant for changing the system key

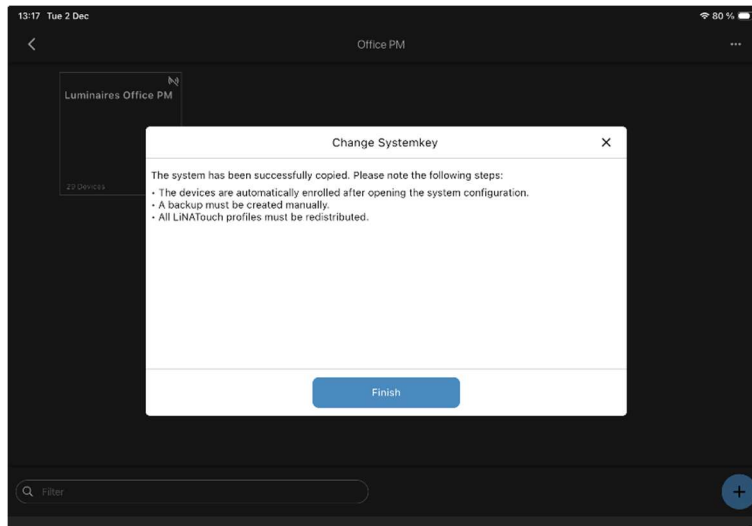

Figure 37: Continue system configuration

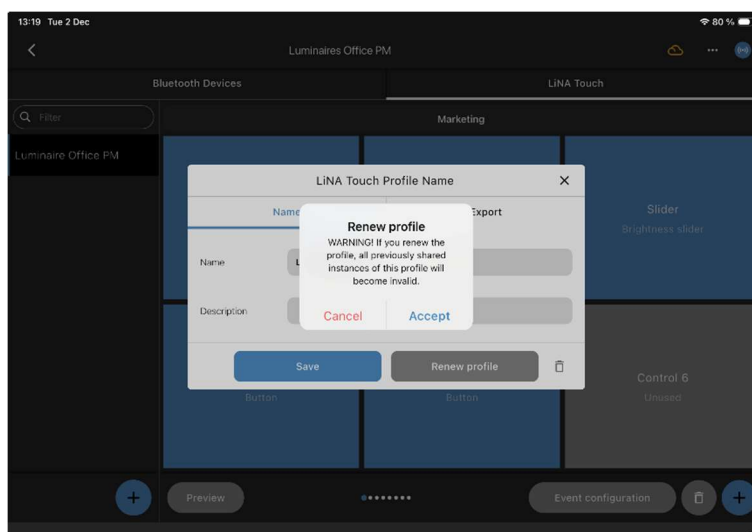

Figure 38: Renew LiNA Touch profile

Please note that users must delete the old LiNA Touch profile on their smartphone or tablet before it is redistributed. After changing the system key, export the profile to users via QR code.

8 USING THE NETWORK OVERVIEW

It is recommended that mesh connections have an attenuation better than -87 dBm. This means that red connections in the network overview should be avoided. To improve connection quality, a repeater can be placed between two nodes. This is not necessary if an alternative, redundant network connection is available but is not currently being used by the network.

You can access the network overview by pressing the three-dot icon. In the menu that opens, select Network Information.

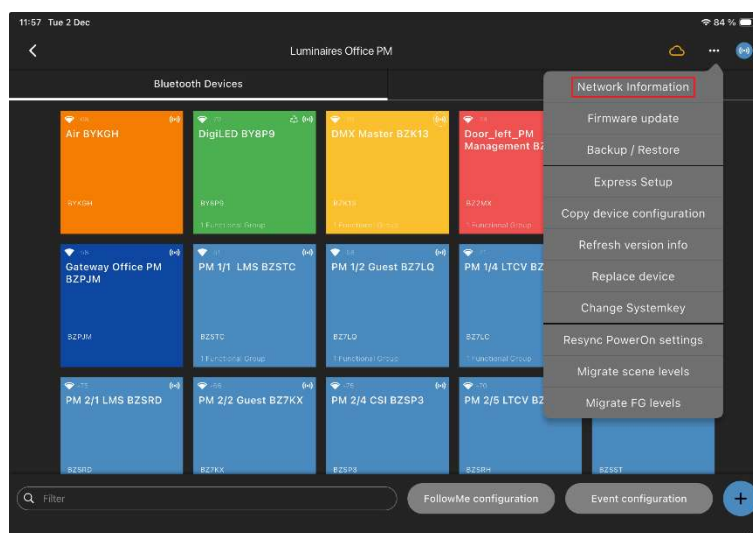

Figure 39: Accessing the network overview

Pressing the three-dot icon opens another menu. Selecting "Restart devices" initiates a rebuilding of the Bluetooth network. This function is useful if you have mesh connections with an attenuation worse than -87 dBm and/or new nodes. Afterwards, you can use the "Reload connections" function to restore the network overview.

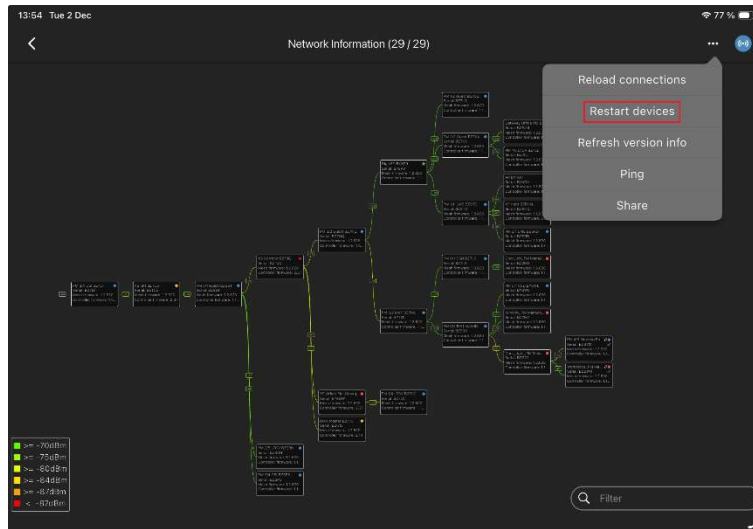

Figure 40: Network overview

It is also possible to restart an individual node by touching the corresponding tile.

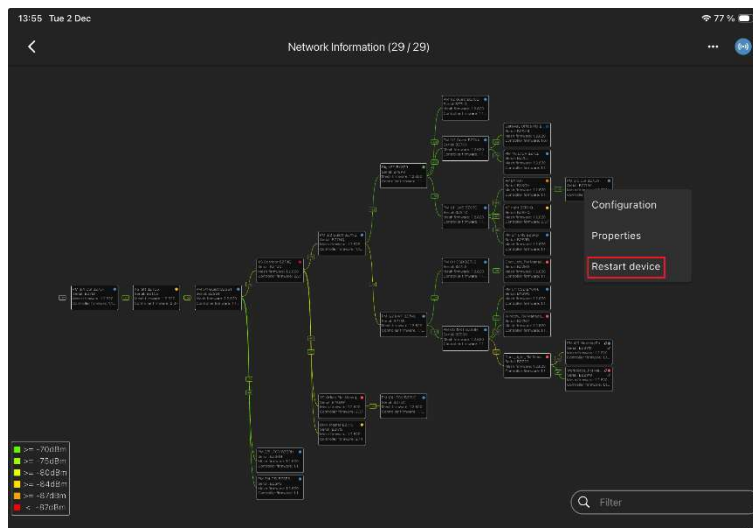
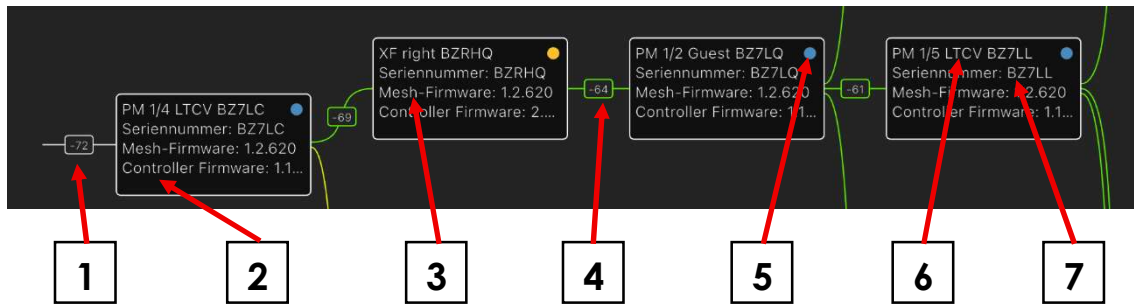

Figure 41: Restarting a single node

The following graphic shows the symbols that appear in the network overview. Each Blu2Light device is represented as a rectangle with information about its firmware, device name, and RSSI value (average received signal strength in dBm).



Number	Description
1	Signal strength [dBm] from the tablet to the node establishing the mesh connection.
2	VS Controller firmware version (cannot be downgraded).
3	Mesh firmware version (cannot be downgraded).
4	Average signal strength between the two Blu2Light devices [dBm].
5	Shortcut link to the node for faster configuration. The dot color corresponds to the tile color in the system overview.
6	Blu2Light device name (customizable).
7	Blu2Light serial number (unique).

9 USING AUTO MODE

To set up an automatic setup, return to the overview shown in Figure 9.

Now press and hold the control panel, Functional Group.

A window called "Setting/Parameters" appears, offering the following choices:

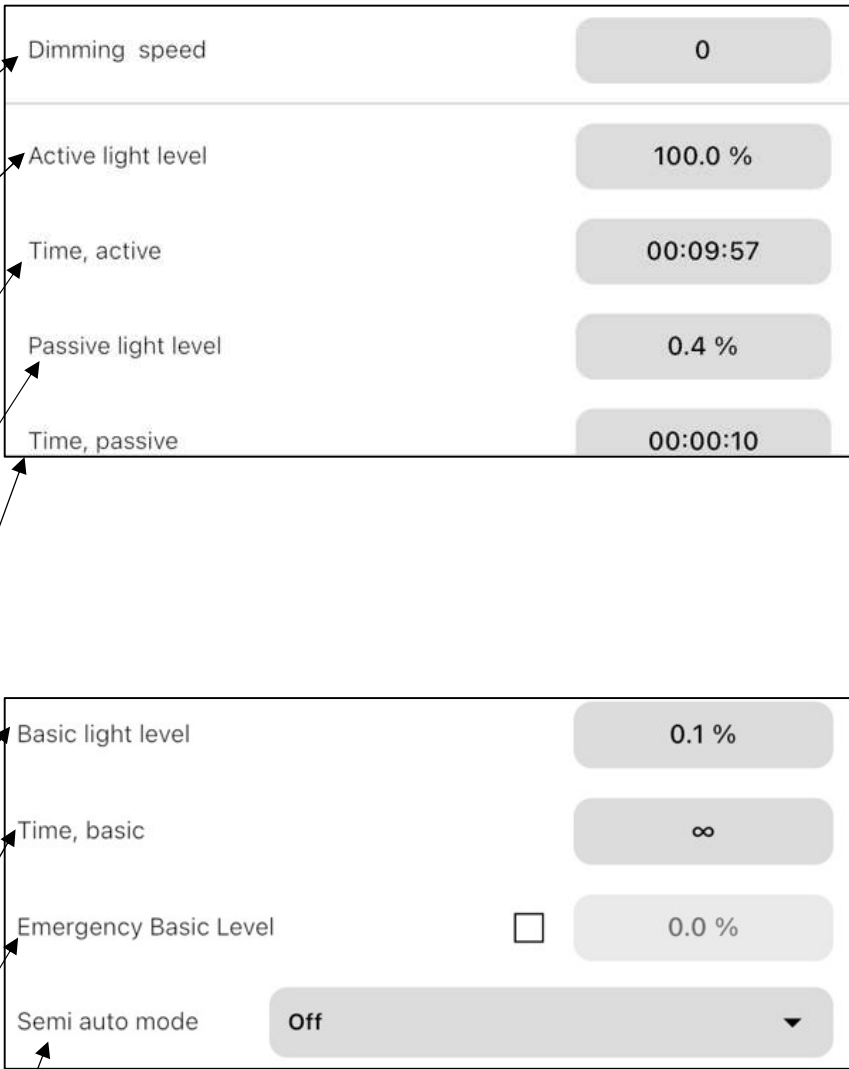

Sets the dimming speed of the stored scene in a DALI value fixed (0-254)

Here the light level for the "Active" state is selected.

Here you can define how long the "active level" is held.

Here the light level for the "passive" state is selected.

Here you define how long the "passive level" is held.

Here the light level for the "basic" state is selected.

Here you define how long the "basic level" is held.

By setting a check mark, you can select which light level is always kept, it is oriented to the basic Level.

Semi auto mode" is used if, for example, buttons are to be used in addition to "auto mode" to interrupt it. It can be activated and deactivated.

If the "Semi auto mode" or "Manual mode" is activated, a "return to auto" time must be set, this defines when automatic mode.

Here you define the state to which the system should return as soon as it is in auto mode again.

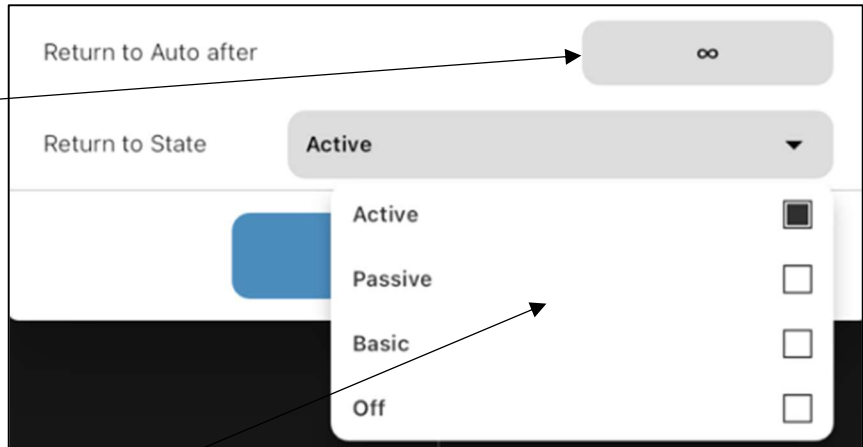

Once you have made all the settings, press "Save", now the configuration should have been applied to the active system.

10 SETTING UP THE TUNABLE WHITE FUNCTION

The following steps describe the "Tunable White" function:

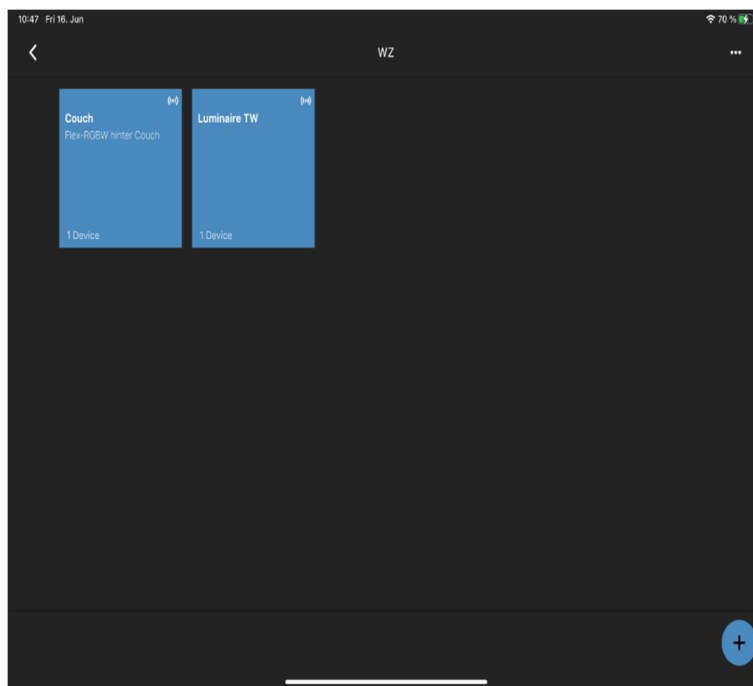

Figure 42: Overview of existing systems

Add your node to the system and enter the configuration.

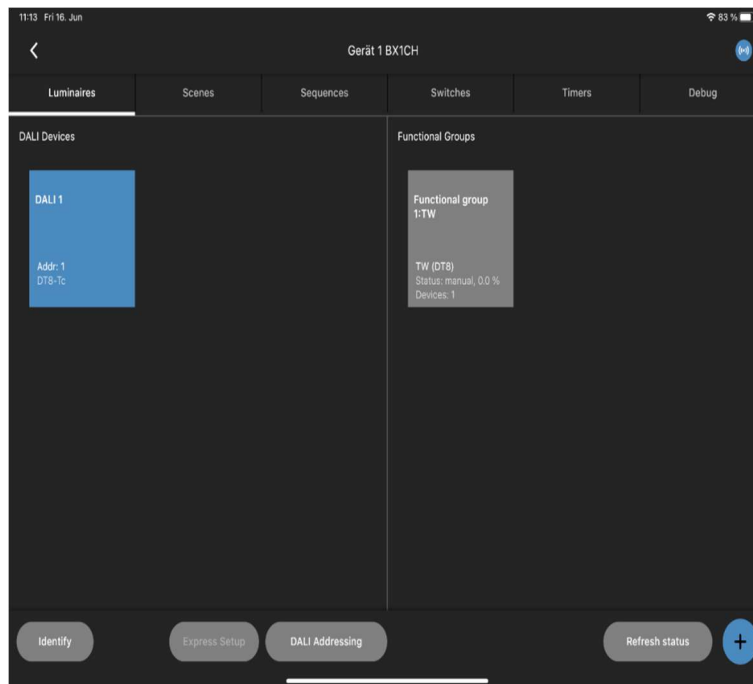

Figure 43: Overview after successful DALI search

Now set it up as you did in the basic configuration.

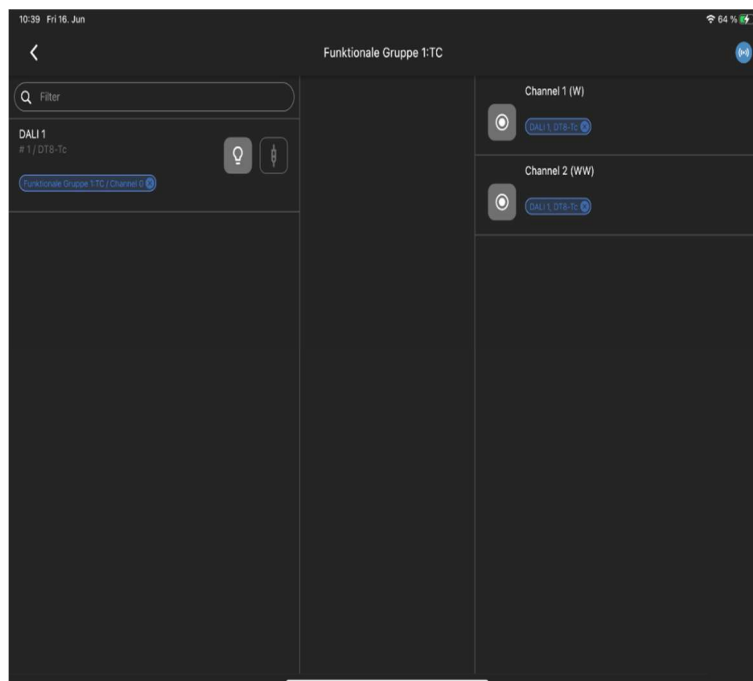

Figure 44: Channel assignment within the functional group

Connect the DALI device to the channels (W=white, WW=warm white) per drag and drop.

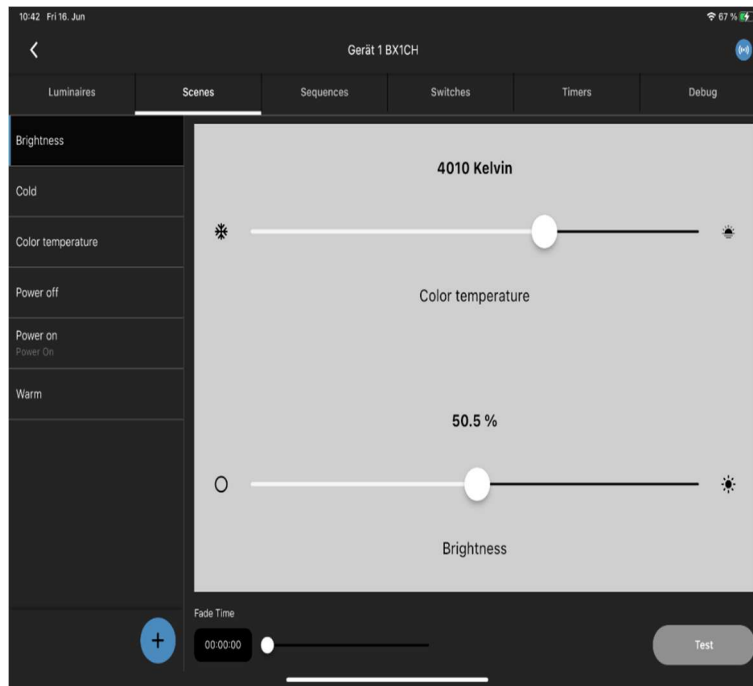

Figure 45: Create the desired scenes

In the next step you can configure the scenes you need. And prepare your touch overlay as you did in the Figures 14 – 21.

11 IMPLEMENTING A DIGILED (186839) + MANUAL CONFIGURATION

For scanning in the Digi LED 4CH please refer to the 3. Step of the manual until you reach figure 7 of the manual.

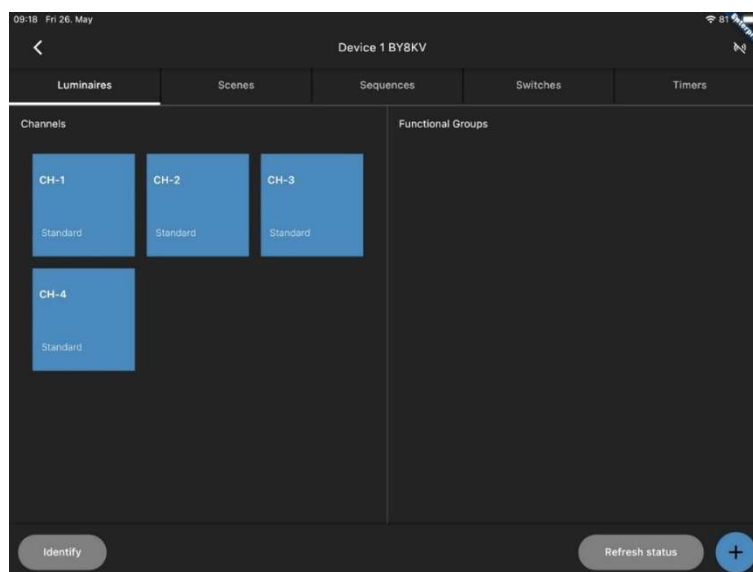

Figure 46: View of the available channels

After that you will see that channel 1-4 have already been recognized by the LiNA Connect App.

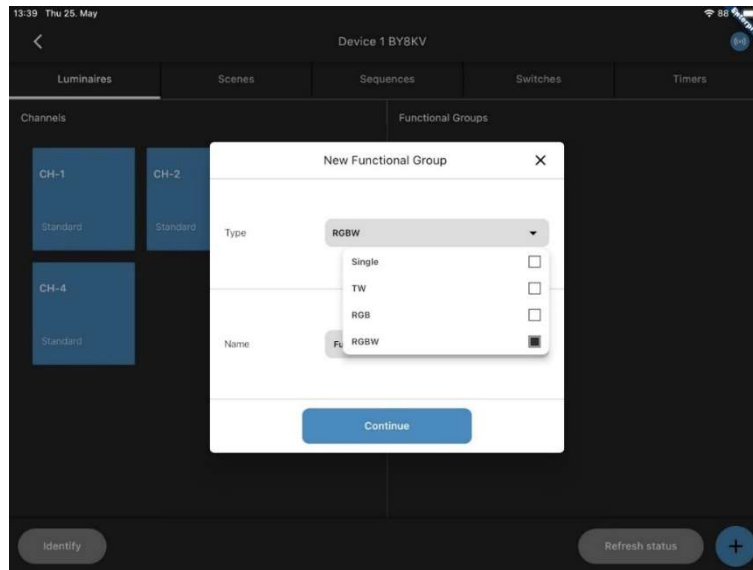



Figure 47: Create a new functional group

As you probably already have mentioned, you can't do an express setup here. Therefore you must create a Functional Group by yourself! To do this, press the  button. Here you must select how many channels your modules have. In this case it is RGBW.

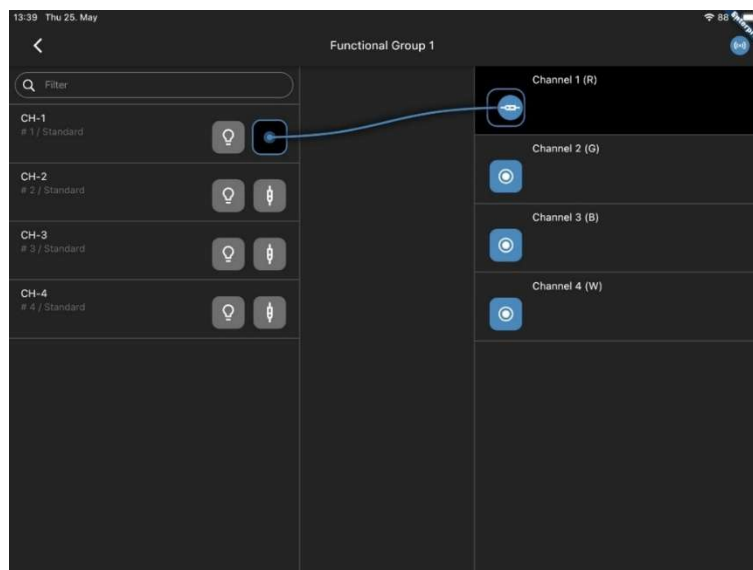

Figure 48: Assigning the channels

In the next step you must connect every channel of the Digiled (R, G, B, W) to every channel of the Functional Group (also applicable for other systems).

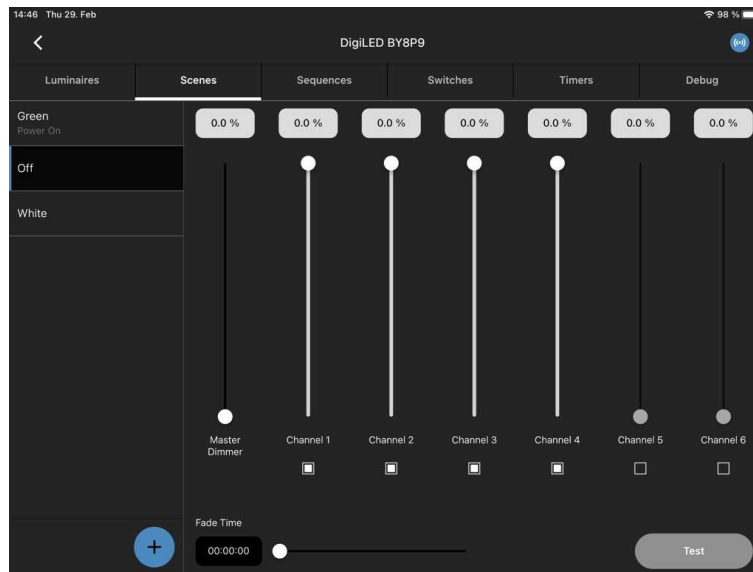

Figure 49: Create the desired scenes

Now we configure our scenes as we did for a simple configuration (Figure 10-12).

For DigiLED you have the option to either use the channel overview or change the type of scene and use RGBW directly, this could make the selection of colors easier. Which should look like this:

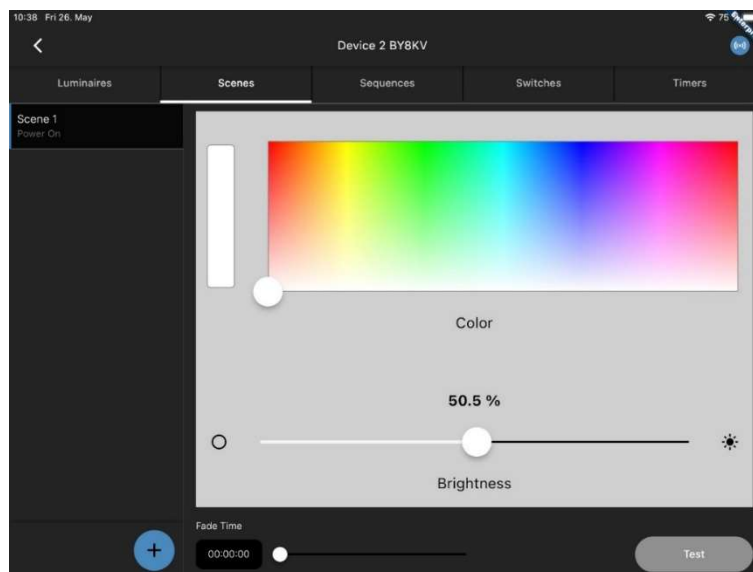

Figure 50: Scene creation with direct color selection

If you have configured every scene you like, go back to Figure 14 and onward to move on.

12 DAYLIGHT CONTROL EXPLAINED

Go to the tab „ Sensor “ to see the possible settings.

Activate the sensor by using this switch.

If using a normal gateway or one in bridge mode, you must activate “send always to mesh” to track or forward sensor information.

If clicking on event configuration, you can add the light regulation to the Functional groups in your system.

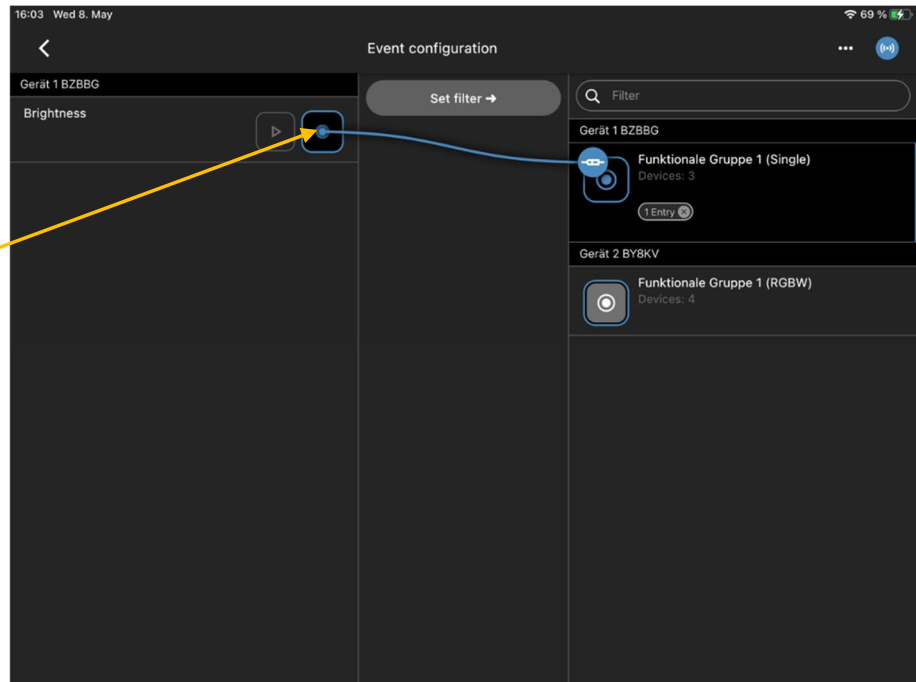
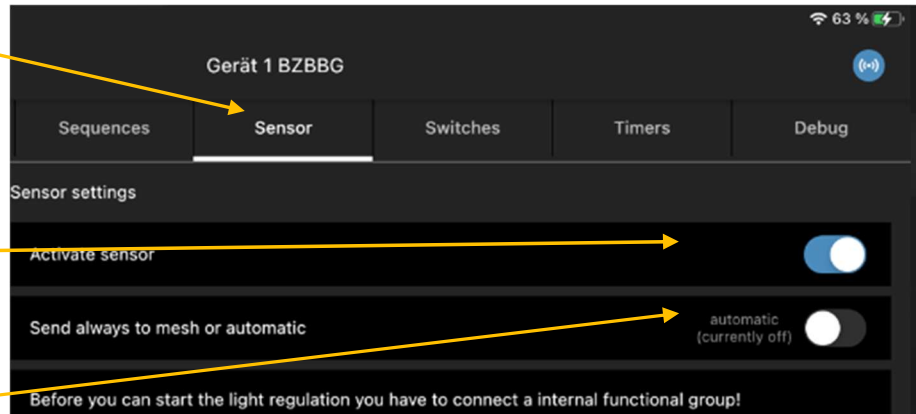

Before you can adjust the light regulation, you must connect an internal functional group.

You can use the slider for the light intensity to try out how bright the light control will be.

Using a lux meter, you can adjust the setpoint lux value in-between 0 - 9999 digits.



The actual sensor value shows the automatic measured sensor value.

The "reference sensor value" shows what is used for the Light regulation (automatic filled, if using the automation)

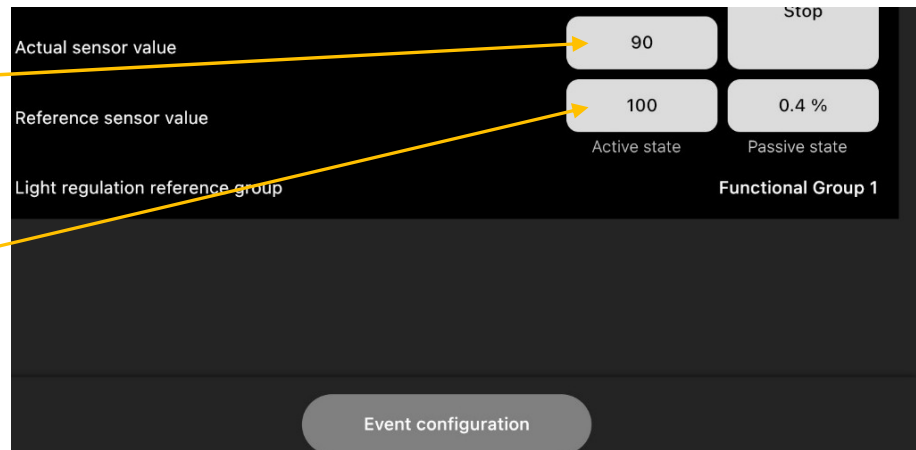

When you are finished with the configuration, press either the upper start button for control according to the manually set sensor value or the lower button for control according to the currently determined sensor value. The reference sensor value will take over the selected sensor value after starting light control. In our case, this is either 100 or 73.

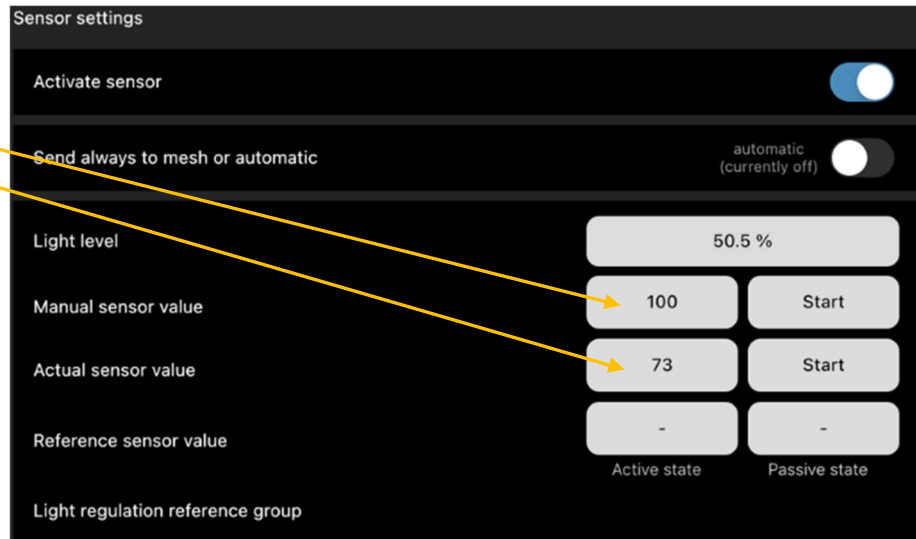

Daylight control can only be started if an event configuration has been conducted beforehand.

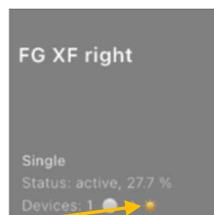

Active daylight control is displayed in the tile of the functional group.

13 LIGHT-THRESHOLD-FUNCTION EXPLAINED

If the current light value falls below the set (manual or current) threshold value, the motion event is triggered, otherwise not. Negation is also possible, i.e. if the current light value exceeds the set threshold value, the movement event is triggered, otherwise not. If the threshold value function is active, the light control reference group is no longer active. The function is only available if a node has a light sensor and a motion detector.

If the threshold value function is switched off, the light control reference group is available, and the threshold value reference groups cannot be set (grayed out). The "Negation" is then also not available and grayed out.

First activate the sensor and "Send always to mesh or automatic" under the Sensor/brightness menu item.

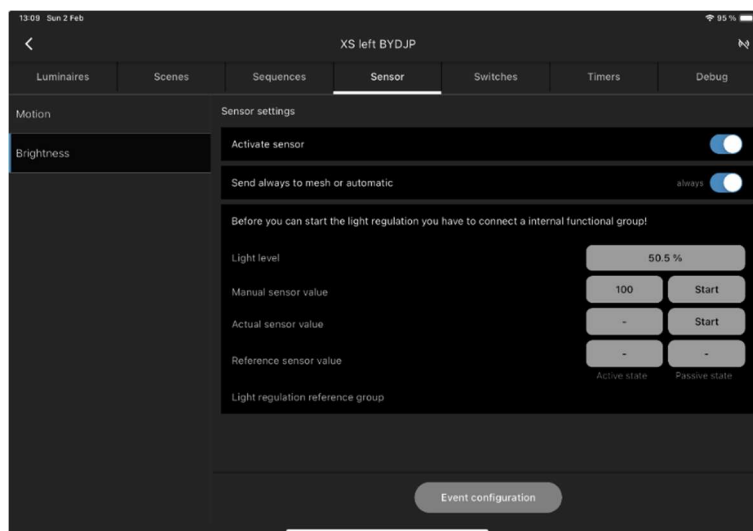

Figure 51: Activating the brightness sensor

Secondly, under the menu item Sensor/Motion, activate the sensor and "Send always to mesh or automatic".

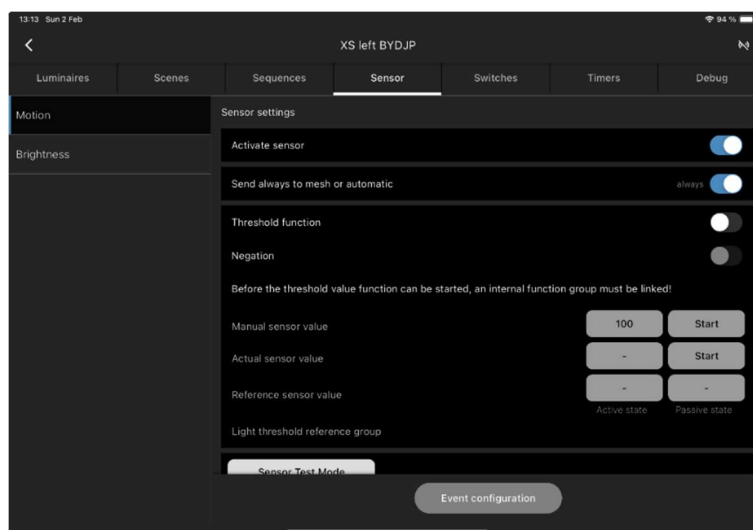

Figure 52: Activating the motion sensor

The threshold function can now be activated. When this is activated, daylight control is no longer possible.

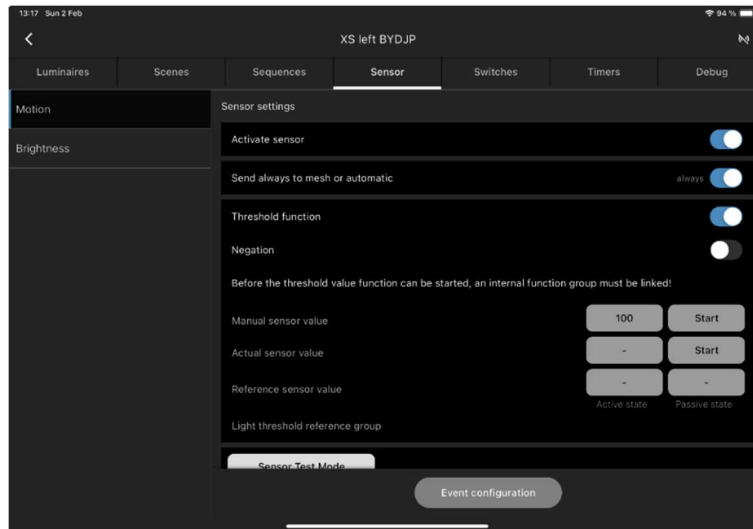

Figure 53: Activating the threshold function

Attention! Before the threshold function can be started, an internal functional group must be linked! To do this, press the “Event configuration” button.

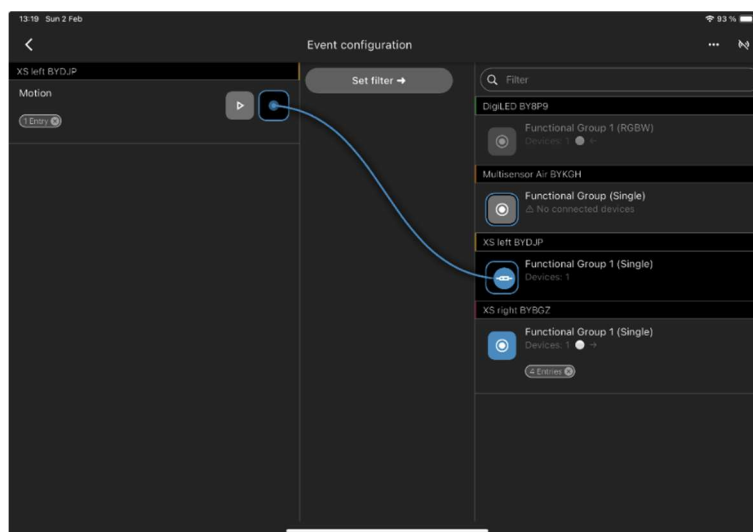

Figure 54: Creating the link to the functional group

After creating the link to the functional group, a selection window opens where you have the option of selecting the desired action.

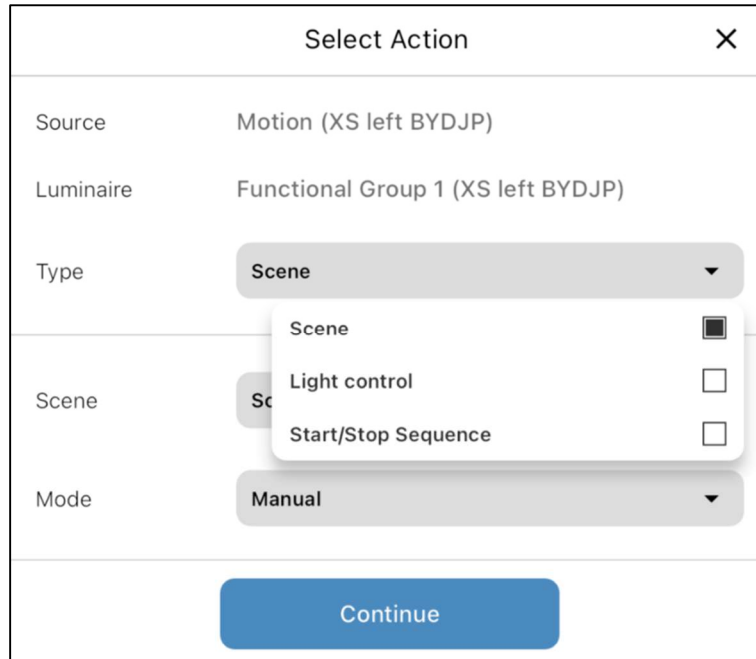

Figure 55: Selection menu for the desired action

Then return to the Sensor/Motion menu. The sensor values can now be set. Select a manual sensor value or the sensor value currently measured by the sensor. After starting the threshold function, the selected sensor value is transferred as the reference value and the function is active.

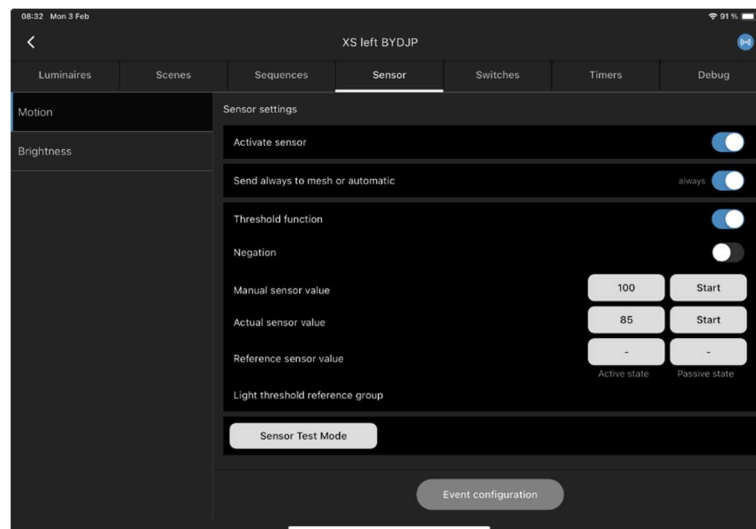

Figure 56: Setting the sensor values is active

14 HOW TO USE MOTION DETECTION

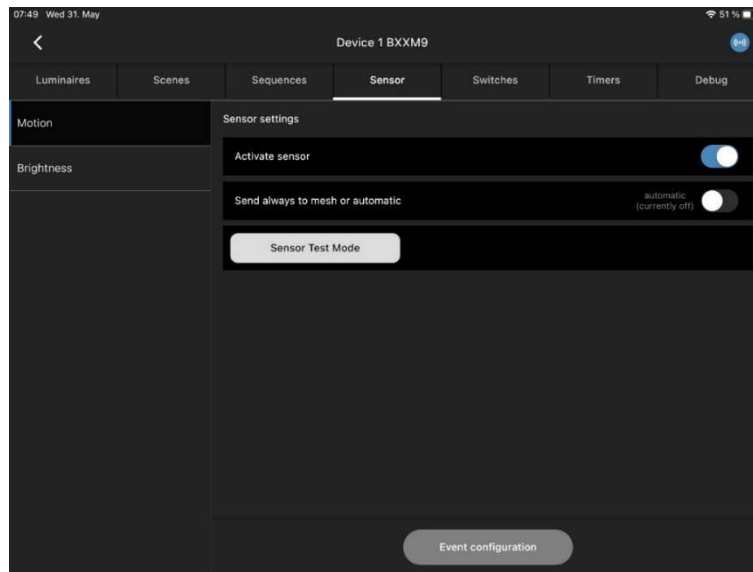

Figure 57: Motion detection menu

Go to the tab “Sensor” and switch on motion detection, if using a normal gateway or one in Bridge mode, you must activate “send always to mesh” to track or forward Sensor Information.

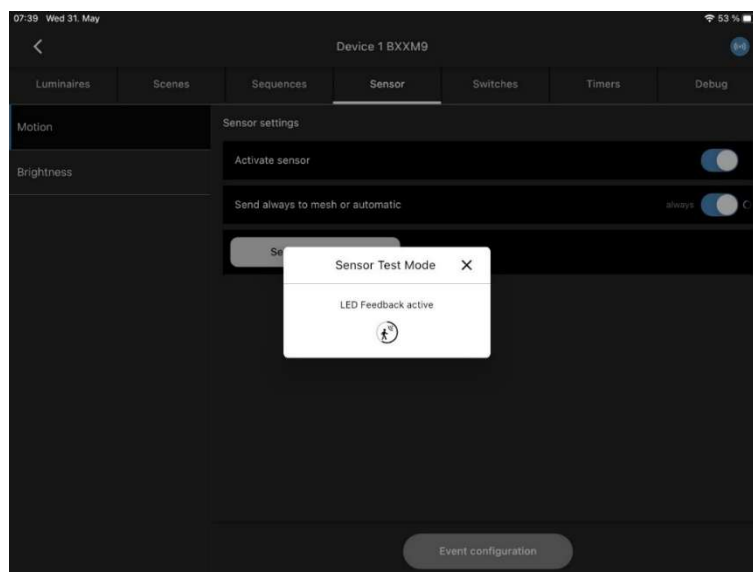

Figure 58: Sensor Test Mode

With the “Sensor Test Mode” you can check your sensor before installing. While active, the sensor indication LED blinks when detecting movement and the circle in “Figure 58” gets filled, it resets every time movement is being detected.

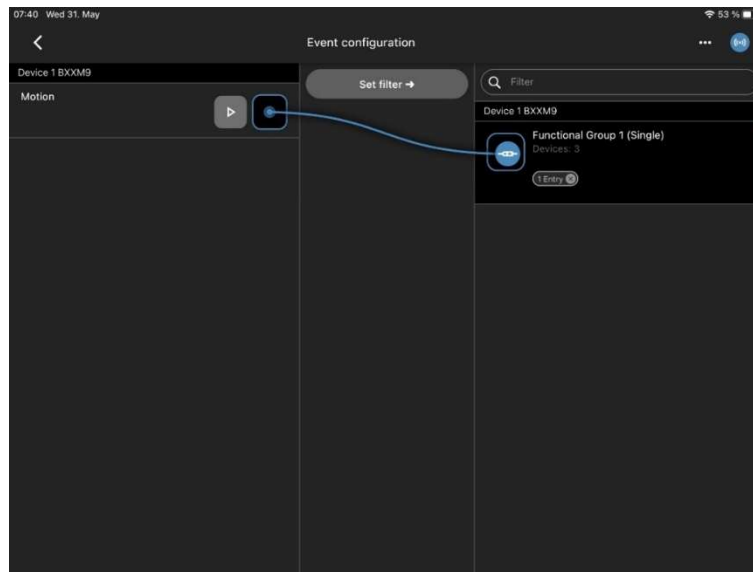

Figure 59: Event configuration Movement

The only thing left to do is to couple the “Motion” function to the “Functional Group” you want it, in the event configuration of the sensor.

15 USING SEQUENCES

A sequence is a series of scene calls; each defined for a specific duration within a function group.

The following points should be noted:

- Regardless of the number of sequences created, a maximum of 64 scenes can be assigned in total. Once this number is reached, no further sequences can be created.
- A maximum of 64 sequences can be created, with each sequence containing only one scene. This limitation necessitates a thoughtful selection of sequences.

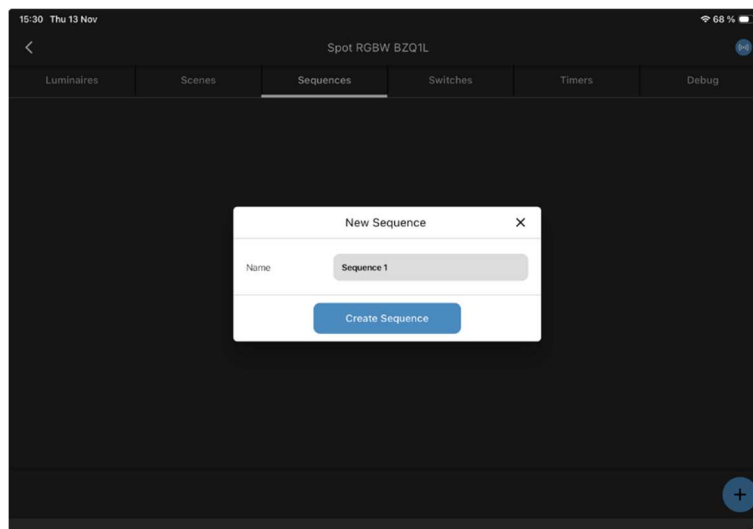

Figure 60: Creating a sequence

Go to the Tab „Sequences” press the button  on the lower right corner and name your sequence as you wish.

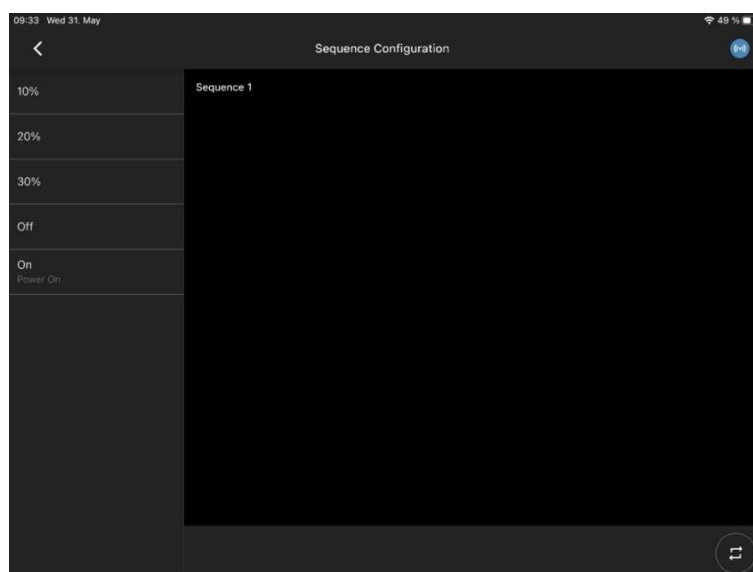

Figure 61: Overview of previously created scenes

On the left side you can see the scenes you have created before.

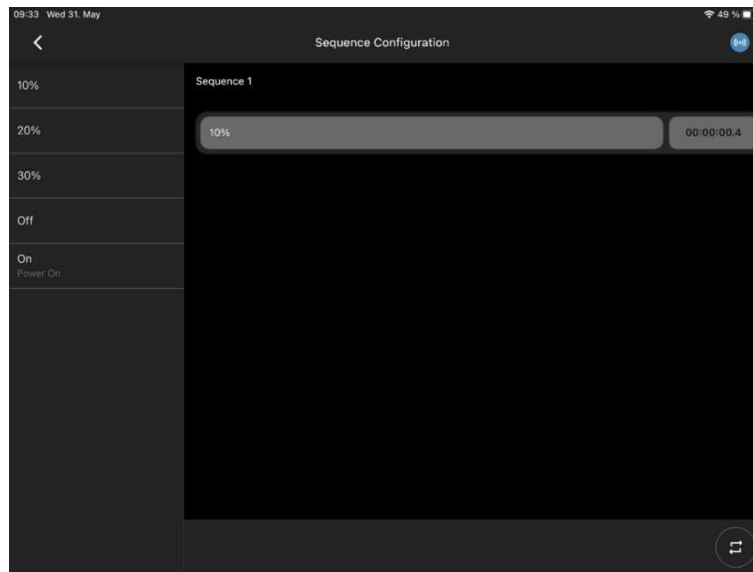

Figure 62: Configuration of a sequence

You can simply add each scene by Drag & Drop in the desired order. Multiple scenes can also be added. You have the possibility to move scenes within the created sequence.

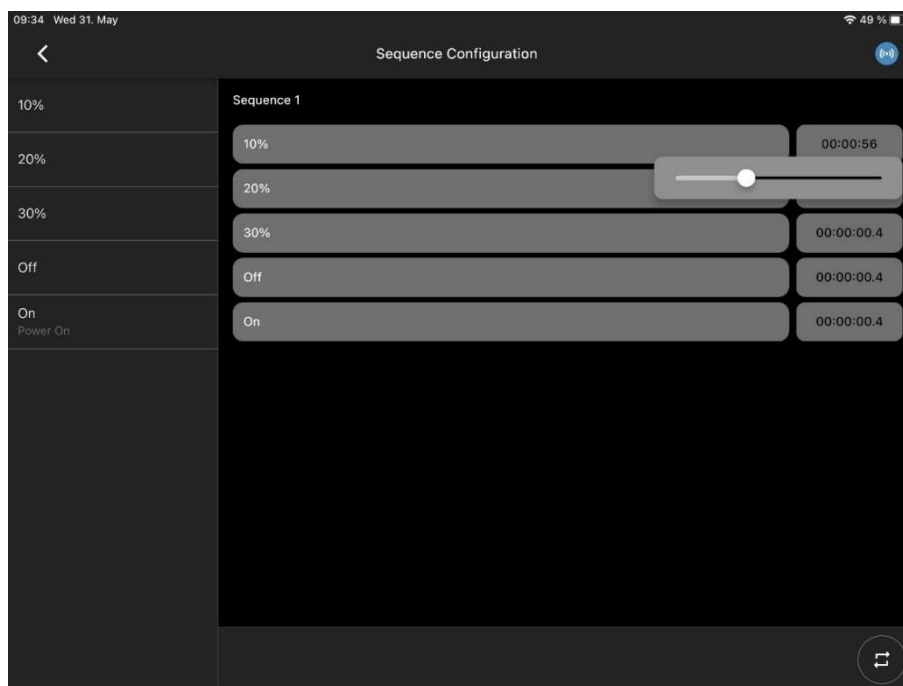

Figure 63: Setting the duration for a scene within a sequence

If you have added every Scene you need/want, you can configure how long every scene will be used until the next scene starts.

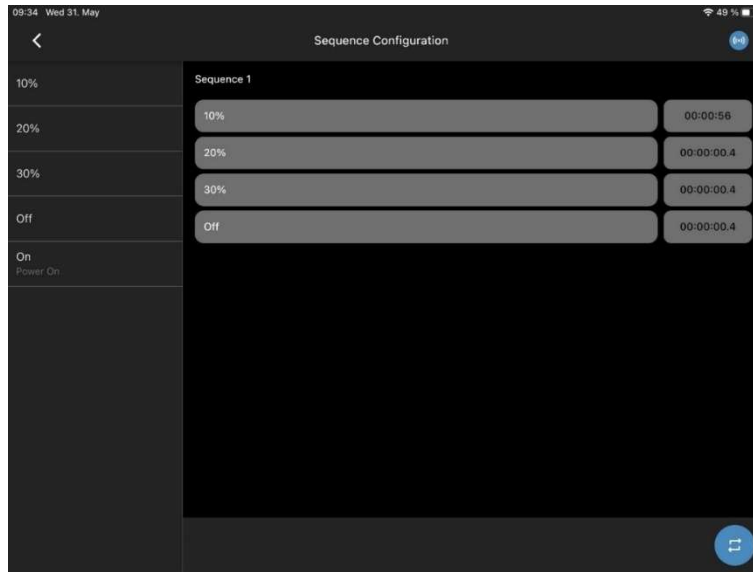

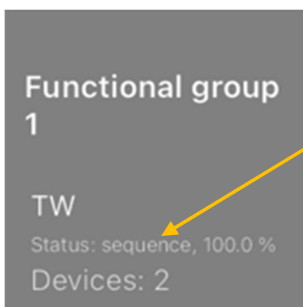
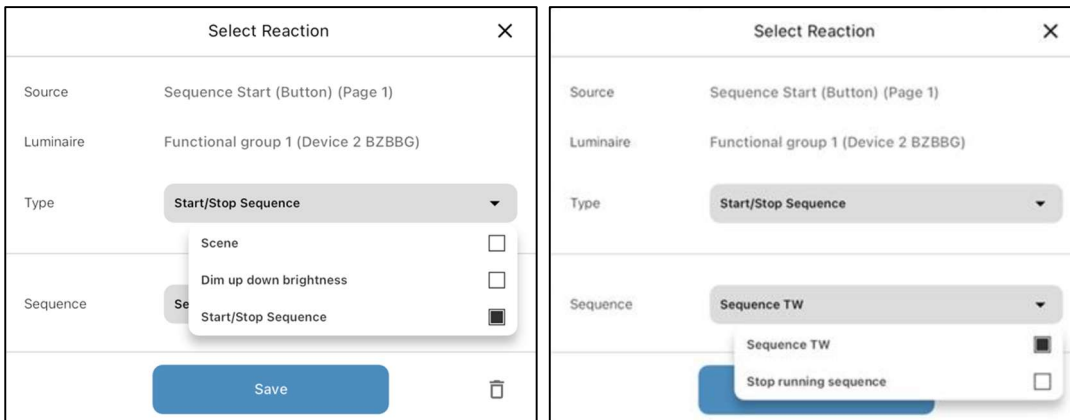

Figure 64: Starting the sequence in a loop

By clicking on the button , the sequence will run in a loop forever. This is indicated by the button , highlighted in blue.

Create the corresponding touch surface as described in figures 14 to 18. You must assign the desired sequence instead of the scene.



A started sequence is displayed in the function group file.

15.1 EVENT CONFIGURATION OF SEQUENCES

In the absence of a click on the designated button , the sequence will be initiated on a single occasion, culminating in the presentation of the final scene. In such cases, the option exists to assign a created sequence to a functional group by means of event linking.

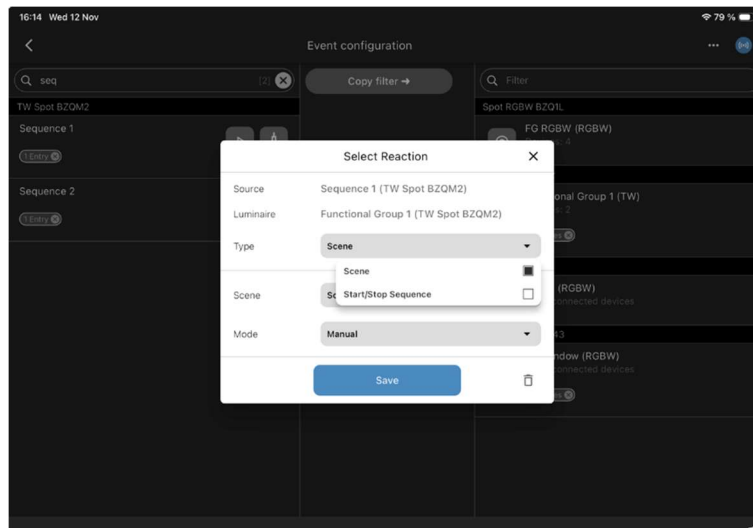

Figure 65: Selecting an action after a sequence has finished

In the dialog shown above, you can select a scene or another sequence to be called after a sequence has finished. You can remain in manual mode or switch to automatic mode to activate motion and/or light control.

15.2 RETRIGGER A SEQUENCE

The "Retrigger sequence" option can be selected to restart a sequence from the beginning. It is configured in the event configuration of a sensor.

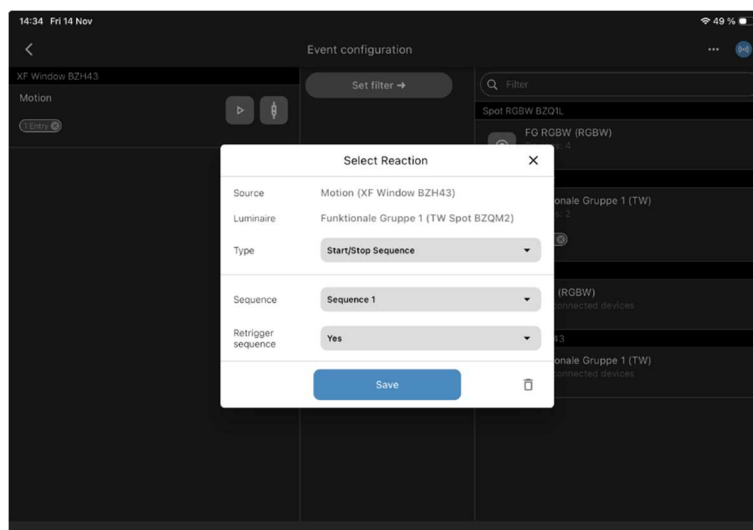
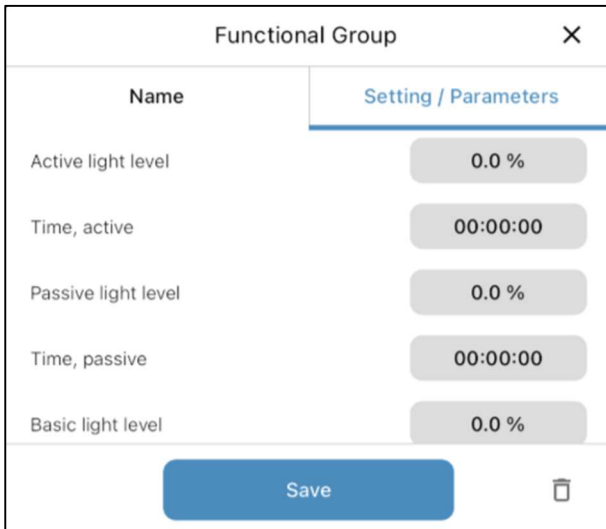

Figure 66: Selecting a sequence with the retrigger option enabled on motion detection

In the sensor settings, activate the "Motion" option. In the subsequent event configuration, link to the functional group containing the desired sequence. Select the sequence and enable "Yes" to retrigger. Save your settings. The linked functional group must be in automatic mode.

If the sensor detects movement, the selected sequence is restarted from the beginning.



If no movement is detected, the sequence runs to its end and then automatically calls up the previously set parameters of the linked functional group. If you do not want the light to cycle through the automatic parameters such as active or passive after the sequence has finished, set all values to zero.

16 ADD AND USE TIMERS

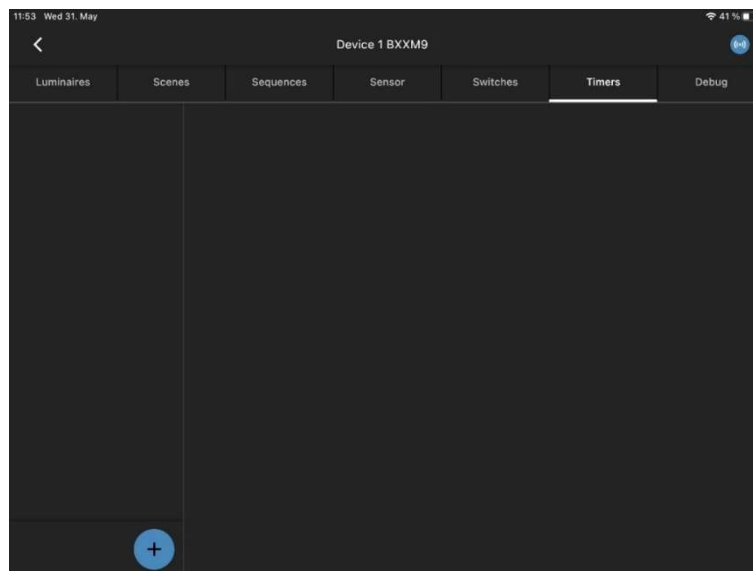



Figure 67: Menu for creating timers

Go to the tab „Timers“ and add a new timer by clicking on the button  in the left lower corner.

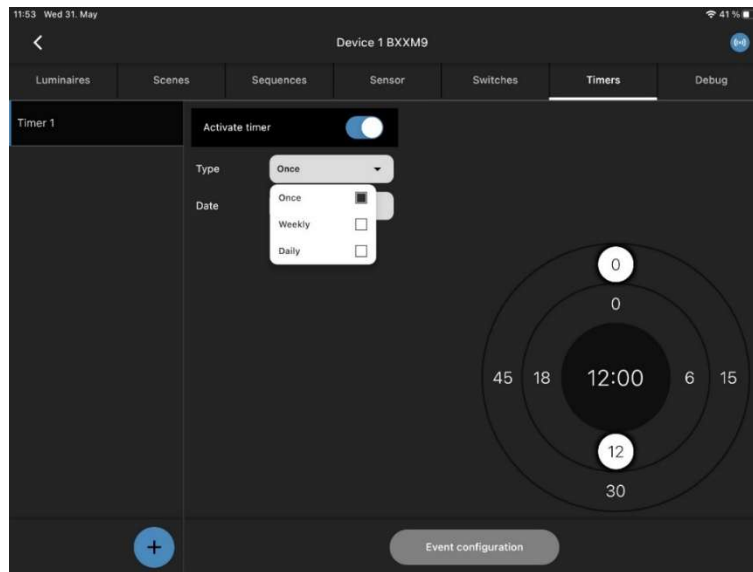

Figure 68: Configuration of timer

Now you have a couple of settings to choose from, “once, weekly, daily”, with different sub menus.

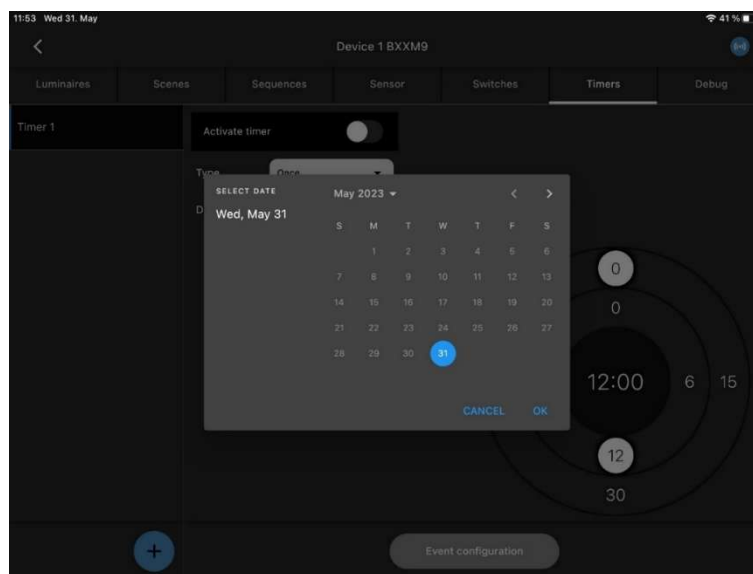

Figure 69: One-time timer

For **once**, you can select a date and time when it shall work.

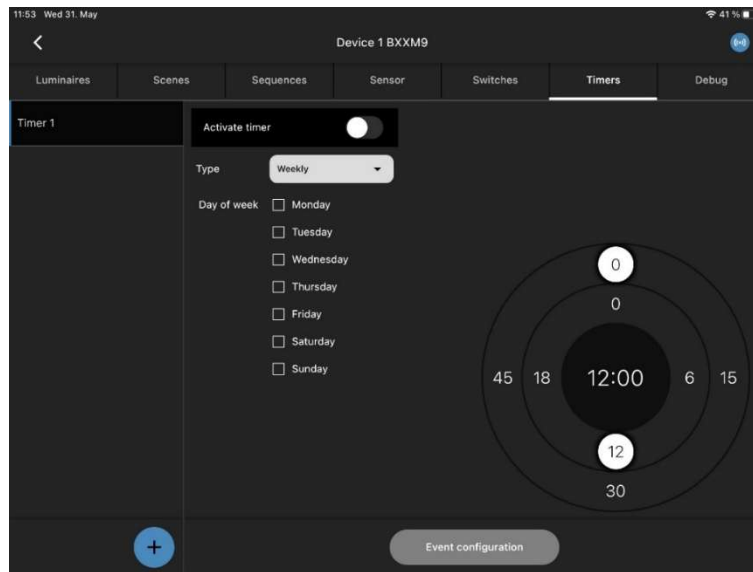

Figure 70: Weekly timer

For weekly, you can select between days and time.

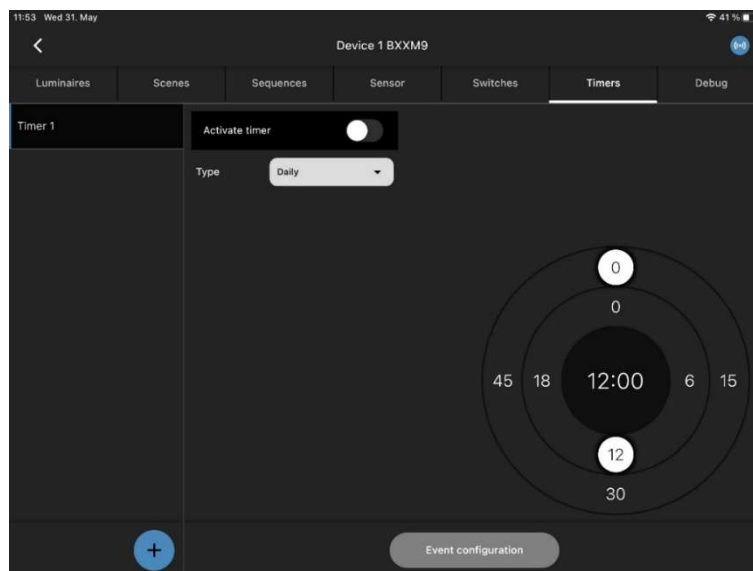

Figure 71: Daily timer

For **daily**, you can select only time for daily use.

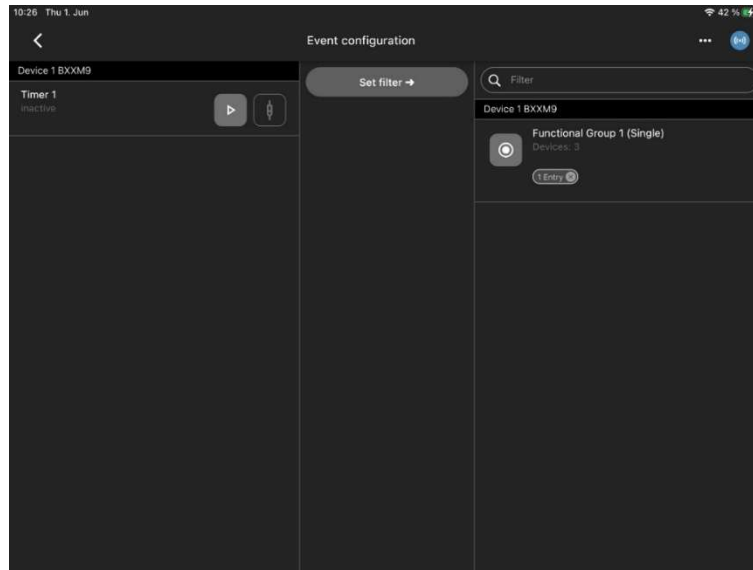

Figure 72: Event configuration Timer

After setting and selecting the Timer the only thing left is to connect the timer to the Functional Group in the event configuration.

Timers are deactivated when the switching action has taken place, and no repetition is assigned. If a node is without power when a timer event occurs, it is repeated when time information is available again. The repetition can take place daily and weekly.

Remarks:

- Make sure that a time reference is available in the system. This can be a device with a GPS receiver, a gateway or a tablet that regularly connects to the system.
- If all nodes in a system lose power, the time reference is lost and is not automatically saved again.
- If a time of a single time event has elapsed during switch-off, the entry is deleted without any action.
- If a time of a repeated time event has elapsed during switch-off, the entry is repeated as if the device had never been switched off.
- When combining timers and power off and on, the power is switched on first and then the timers that need to be repeated are executed.

17 USING THE AIR SENSOR

Our air sensor has the options to be used as a motion or brightness sensor which can be configured same, as described in chapter 9 to 11.

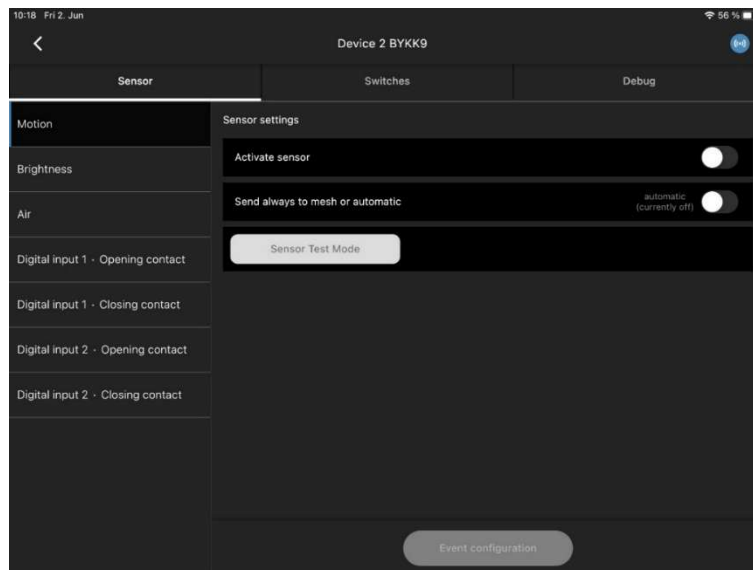

Figure 73: Menu of Multisensor Air

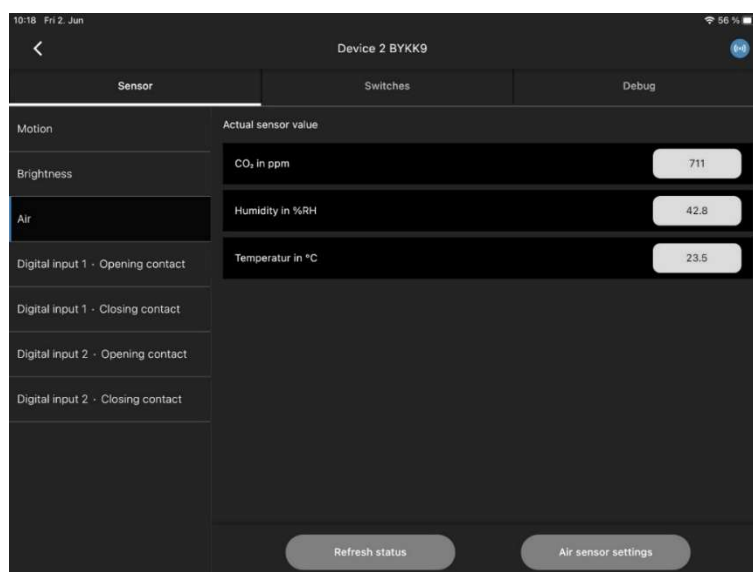

Figure 74: Current sensor values

You can see the values of CO₂, humidity in %RH and temperature in °C in the Tab „Air“.

The AIR sensor settings allow you to configure the update intervals as well as the lower and upper thresholds. If the update interval is left at 0, no data transfer occurs. It is recommended not to choose too short an interval to avoid unnecessary data traffic. A value of one minute or more is recommended.

Underneath you have the option to switch on and off the air quality indicator and define the orange and red threshold, the LED is turned on in default.

Air sensor settings		✕
Brightness refresh interval (sec)	56	▼
Brightness low threshold	100	▼
Brightness high threshold	300	▼
CO2 refresh interval (sec)	60	▼
CO2 low threshold (ppm)	800	▼
CO2 high threshold (ppm)	1400	▼
Temperature refresh interval (sec)	60	▼
Temperature low threshold (°C)	16	▼
<input type="button" value="Save"/>		

Figure 75: Settings of sensor

Air sensor settings		✕
Temperature high threshold (°C)	36	▼
Humidity refresh interval (sec)	60	▼
Humidity low threshold (%RH)	30	▼
Humidity high threshold (%RH)	65	▼
Air quality indicator on/off	<input checked="" type="checkbox"/>	
Orange threshold	800	▼
Red threshold	1400	▼
<input type="button" value="Save"/>		

Figure 76: Air quality indicator

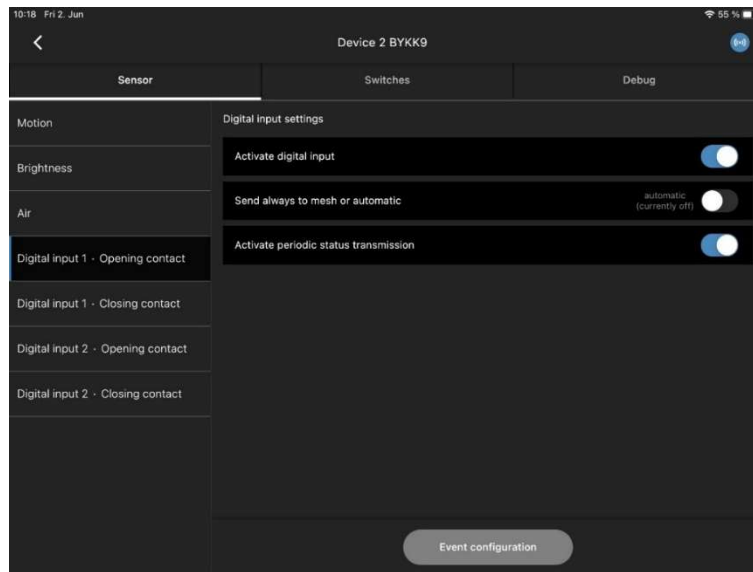

Figure 77: Setting the digital inputs

For switching on and of air conditioning, we have 2 digital inputs where we can detect openings and closings of a window. This function can only be used in a cloud solution, as well as the usage of the air sensor values (CO₂, humidity etc.).

18 USING THE BLU2LIGHT RELAIS

This mains-powered, 2-channel device is used to control any load. Note the maximum switching capacity of 4 A resistive load per channel, as specified in the datasheet. Both channels can be combined with blinds or roller shutters. The device is available in three different pre-configured modes:

Relay mode: pre-configured for use as a relay.

Jalousie mode: pre-configured for use with blinds.

Blinds mode: pre-configured for use with roller shutters.

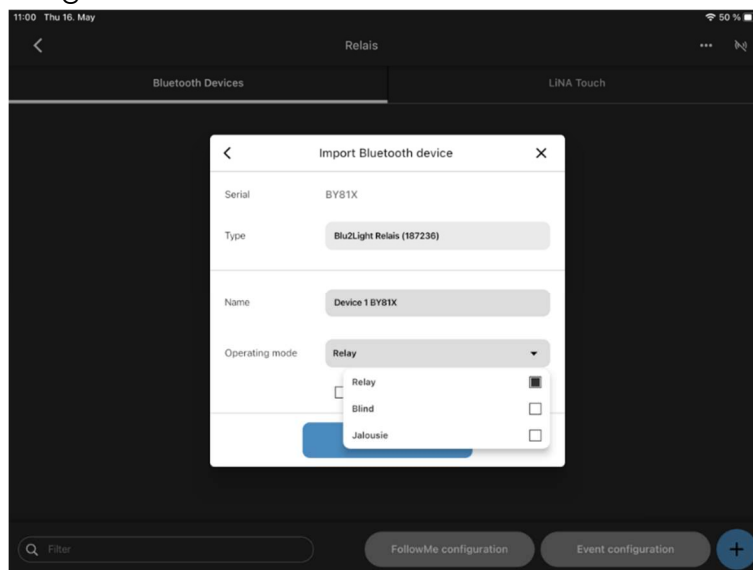

Figure 78: Selection of operating mode

Start scanning in your node and go into the settings as in "Figure 2". Now you can either use the relay mode, roller shutter mode or the blinds mode by changing the wiring on the relay itself and set the mode to the function you need. **Have in mind that this is only a relay, meaning that all scenes you configure over 0 % are on state "on"!**

Please note that changing the mode will reset all function groups associated with your relay! You must select the mode after scanning the node!

18.1 MODE JALOUSIE

Start the scan in your node and select the jalousie mode.

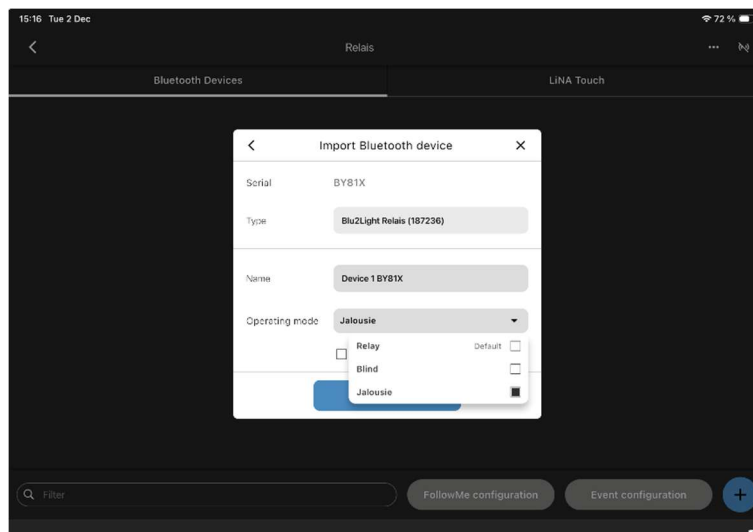

Figure 79: Selecting the jalousie mode after the scanning process

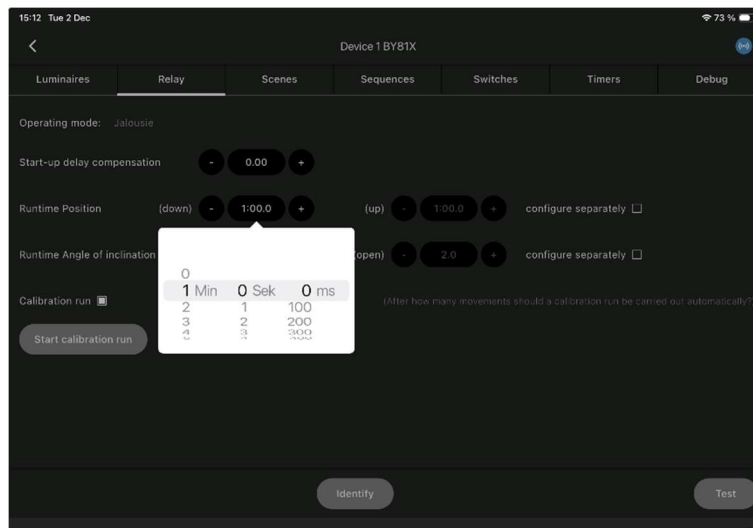
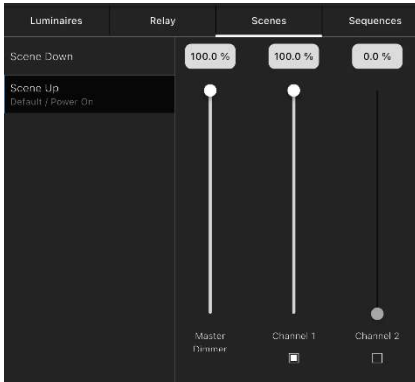

Figure 80: Jalousie mode

When you lower your blinds, the relay times the time it takes for them to reach the end of the track. You can set a start-up delay (observe the motor's technical data) and change it manually at any time (Figure 80). The set travel times must match the time it takes the blind and slats to move from one endpoint to the other.



Using the scene settings for FG 1 (blind) and FG 2 (slats), you can specify the percentage of movement for the blind as well as the operating angle of the slats. Please note that only Channel 1 controls the movement. You must create separate scenes if you require different target positions.

The lighting equivalent is used, provided it is not nighttime. This means 100% corresponds to "open" and 0% to "closed."

Errors of a few cm can occur if intermediate positions are approached several times (e.g. from 30% to 60%). However, this can be rectified by moving to an end point. A reference movement is always carried out in the direction in which the desired end position is reached more quickly. This can therefore be up or down.

The number of incomplete journeys after which automatic calibration should take place if the end point is not reached can also be set. There is also the option to start the calibration manually by pressing the "Start calibration run" button. This moves the blind to the nearest end point and back to the current position.

18.2 MODE BLIND

Start the scanning process in your node and select the blind mode.

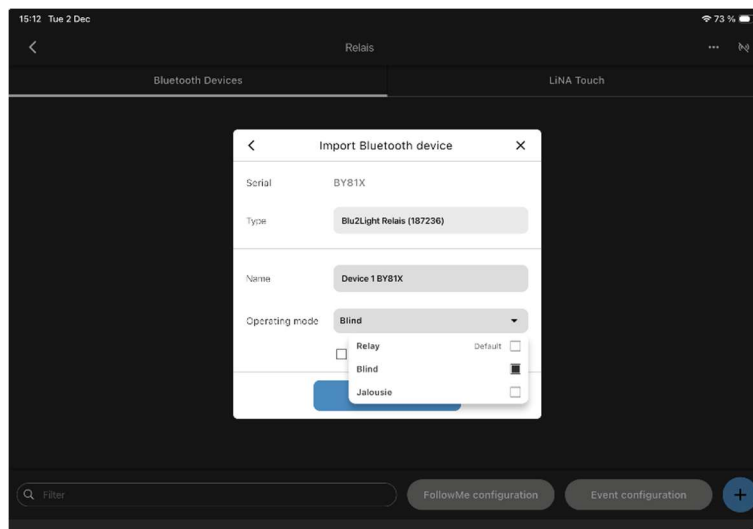

Figure 81: Selecting the blind mode after the scanning process

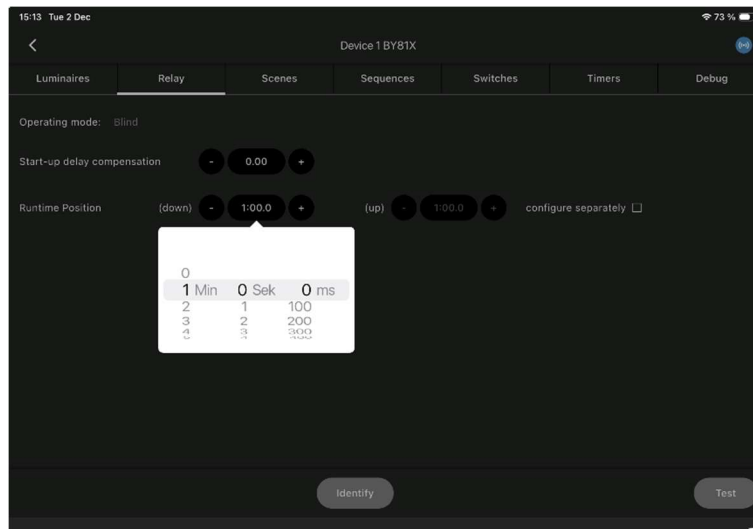

Figure 82: Blind mode

The set running time must match the time that the roller shutter needs to move from one end point to the other. You can set a start-up delay (observe the motor's technical data) and change it manually at any time (see Figure 82). Furthermore, you have the option to configure the runtime for downward and upward movement separately. Calibration takes place automatically after each approach to an end position.

18.3 MODE RELAY

In Relay mode, non-dimmable lights or similar devices can be controlled. Start the scan in your node and select Relay mode.

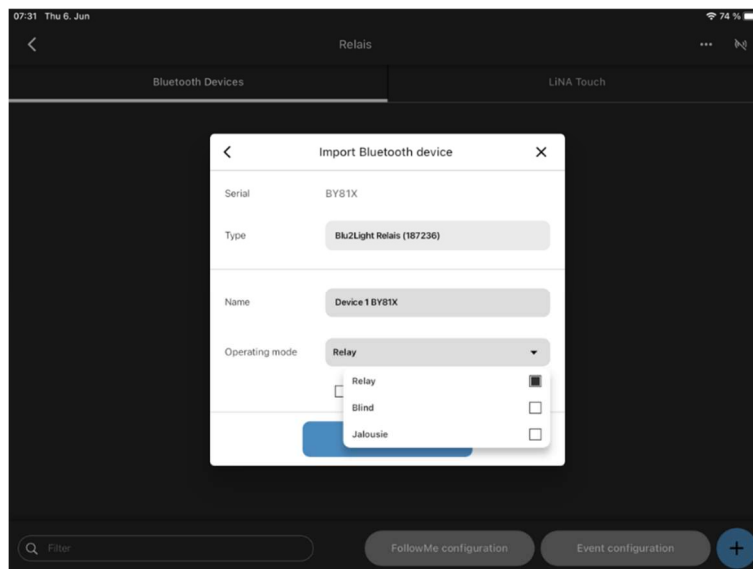

Figure 83: Relay mode

After importing the device in relay operating mode, you will see the following view after opening, with 2 preset channels and functional groups each.

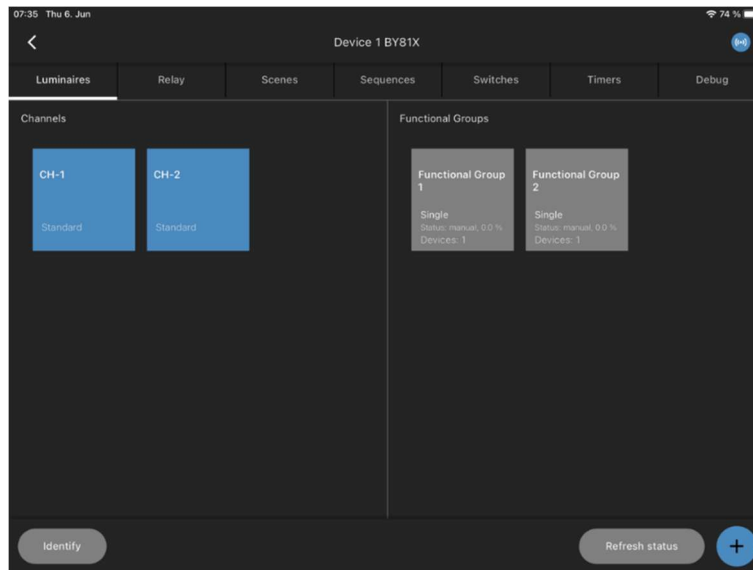

Figure 84: Overview of channels and FGs in relay operating mode

When creating scenes, the on and off scenes are set with channel 1.

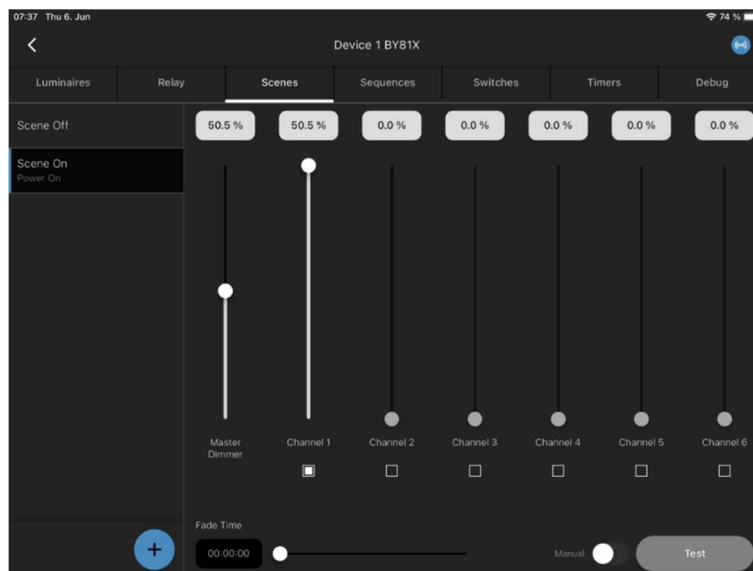

Figure 85: Menu for creating scenes

Please note that this is only a relay, i.e. all scenes that you configure above 0 % are in the “on” state!

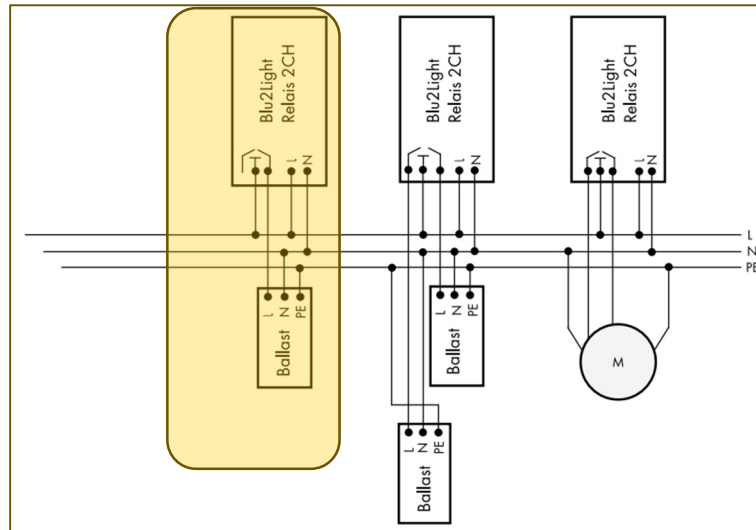

Figure 86: Wiring diagram

We are looking at the coloured wiring of the relay. Even if you wire the left relay contact instead of the right one, you must set channel 1 when creating the scene.

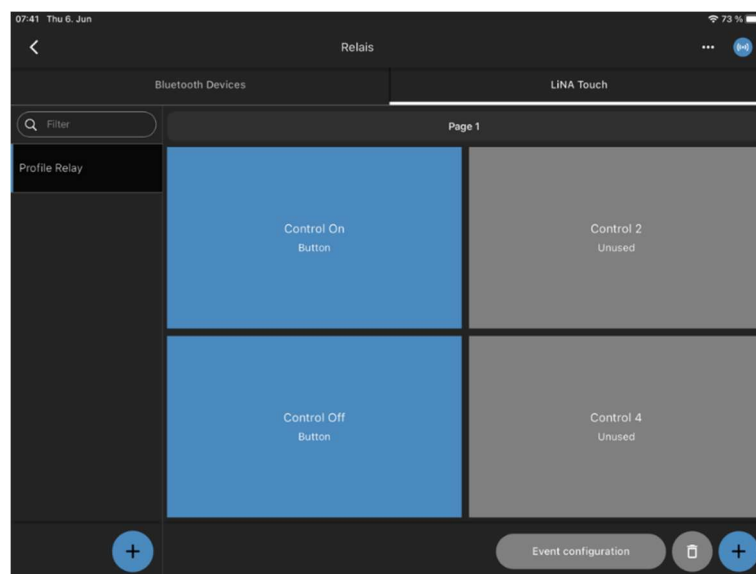

Figure 87: Creating the touch user interface

In the event configuration, you must note which relay contact you have wired. If you use the right-hand contact, the events must be linked to functional group 1 in the event configuration; if you use the left-hand contact, link the events to functional group 2.

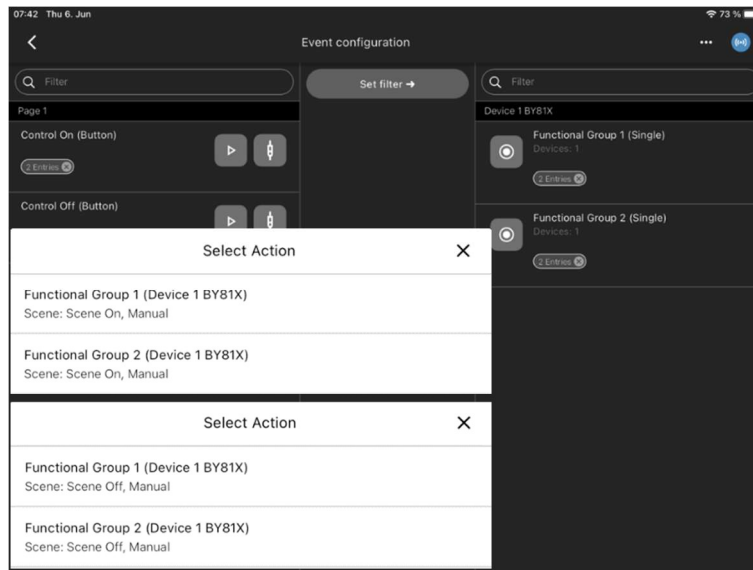

Figure 88: Event linking with both FGs

However, you also have the option of linking the events to both functional groups. This means that both contacts are switched.

19 USING THE B2L CONNECT PB4

The PB4 push-button interface allows you to trigger system events using standard light switches.

NOTE: Continuously pressing the PB4 inputs is not permitted.

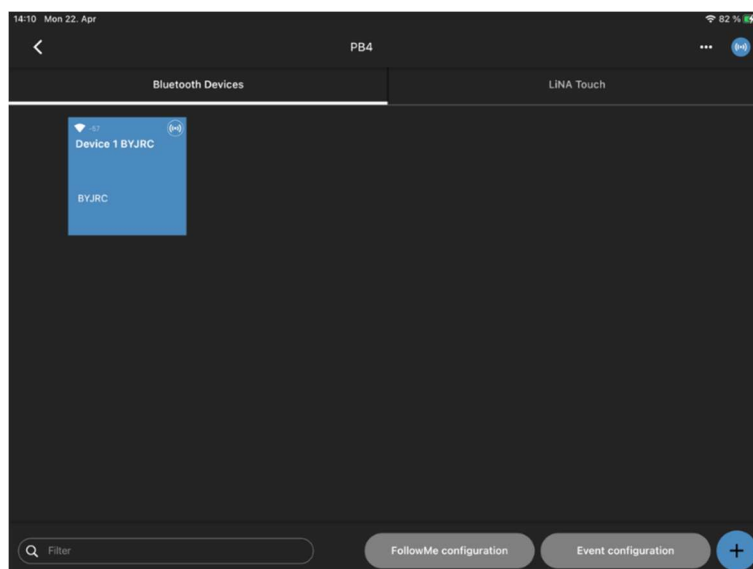

Figure 89: View after scanning

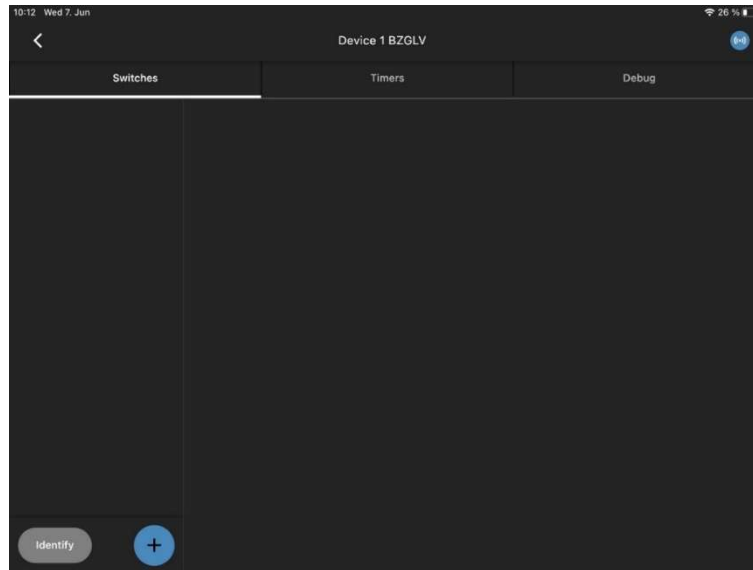

Figure 90: Menu of Blu2Light Connect PB4

By scanning PB4 and clicking on the Node you will notice that you have the Option to add another En Ocean Switch. You can also add Timers.

The button inputs can be configured by opening the event configuration (Figure 89).

There you will see the button inputs of your Connect PB4 (Figure 91).

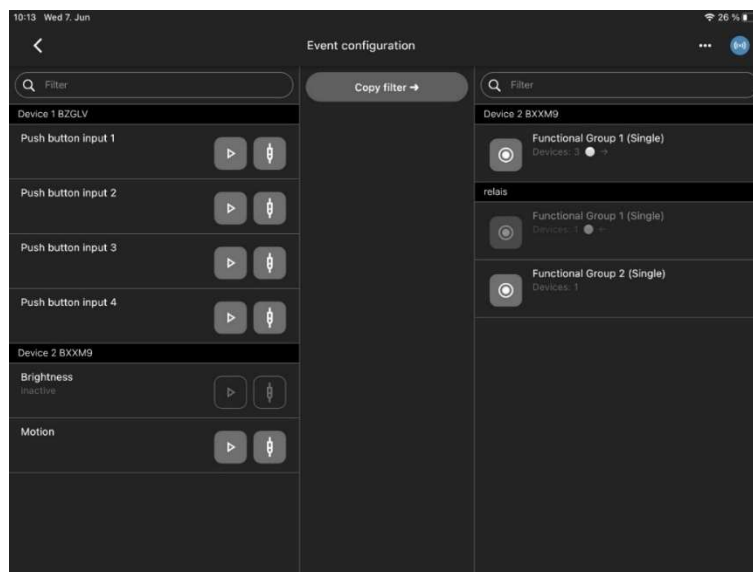

Figure 91: Assignment of the push-button inputs

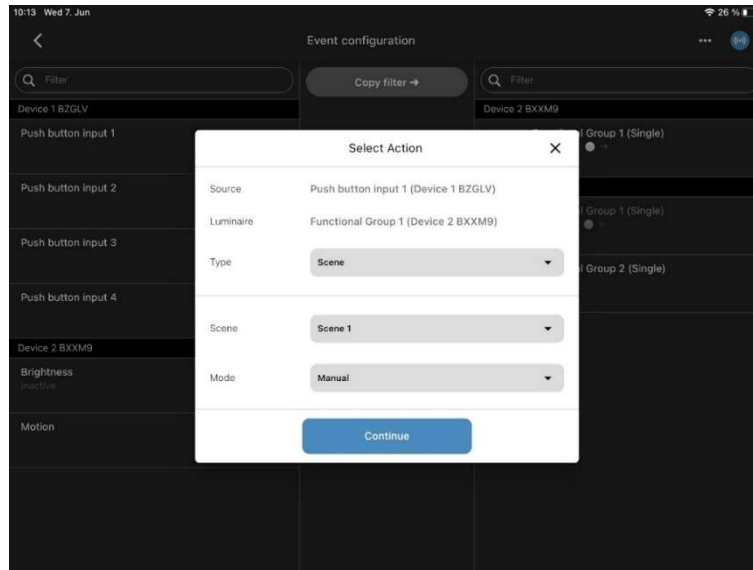

Figure 92: Linking the button inputs with the desired action

By connecting the nodes to the desired functional group, you can decide which action shall be triggered by pressing the switches, connected to the output according to the scenes you configured in "Figure 10 to 12". In addition to scenes, other actions can also be selected, such as adjusting the brightness, starting and stopping previously created sequences, or the one-button function.



When selecting brightness, you decide whether you want to dim the light level up or down by pressing a button. The step size determines how quickly the light dims up or down. A smaller value results in a slower dimming speed and a longer dimming time.



When selecting Start/Stop Sequence, you can start or stop a previously created sequence by pressing a key.

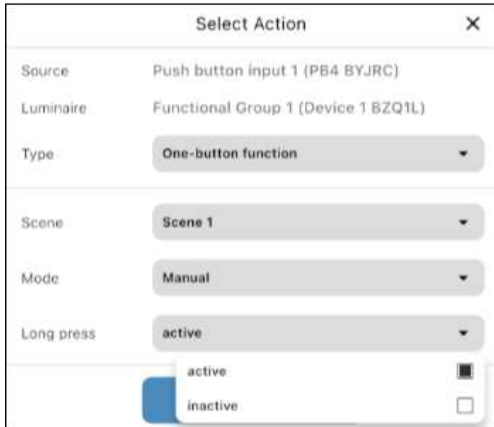

This function allows you to control a function group with a single button press. It's important to note that only one button press can be linked to one function group, and no more. With "Long press inactive" selected, pressing the button will only turn the light on or off. With "Long press active" selected, the new state is always in manual mode. The dimming direction is "upwards" by default.

The dimming direction changes with each dimming action: If the brightness is down or up, then the direction is in the only possible direction. If the brightness is 0% at the start of a long press, the dimming direction is up. If the base brightness is 100% at the start of a dimming process, the dimming direction is down. A step size of 30 is used as the default dimming speed. At the start of a long press, the color value of the button event scene from a short press is adopted if it is not already used on the function group. The current brightness is maintained in this case.

20 INCLUDING AN BLU2LIGHT REPEATER

For better connection between the nodes, you can use a repeater. The repeater can only be used to strengthen the mesh and is simply scanned in. The device can't be configured.

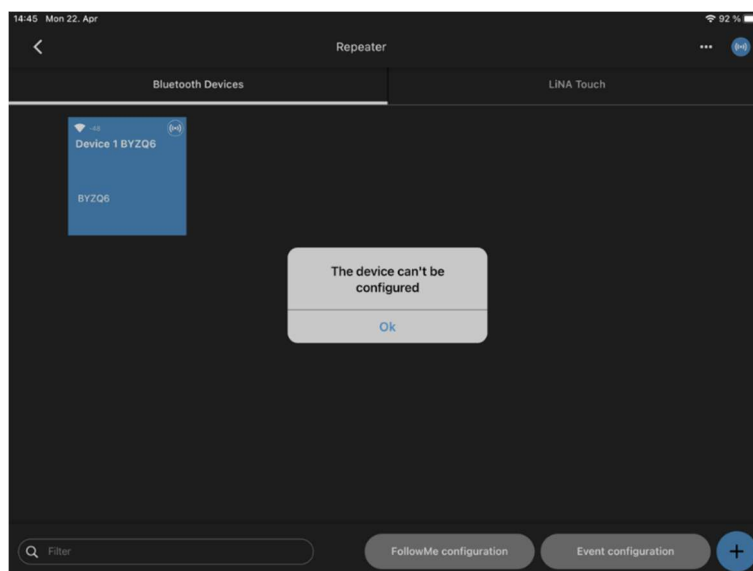

Figure 93: View after scanning

21 INCLUDING THE BLU2LIGHT CONNECT DMX CONTROLLER

Start scanning the node in your system and go into the settings as in "Figure 2". You can now select either receiver, master or master follower mode by setting the mode to the desired function. If you want to change the mode for a device, the corresponding device must be deleted from the system configuration and scanned in again.

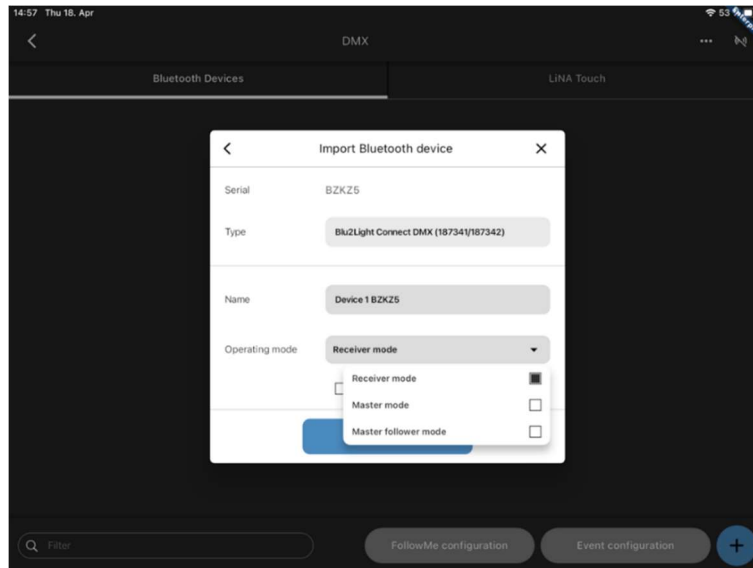

Figure 94: Selection of operating mode

21.1 RECEIVER MODE

This mode is used when the device is connected to a DMX controller. After scanning the Node, please select the "Receiver Mode" and press the button "Continue".

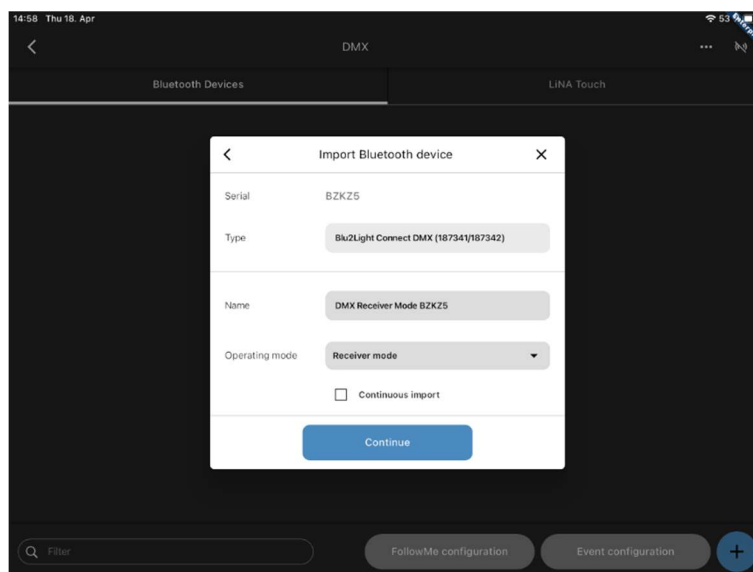

Figure 95: Receiver mode

By pushing the button for the commissioned device, you will come to the following overview. There are 32 configurable channels.

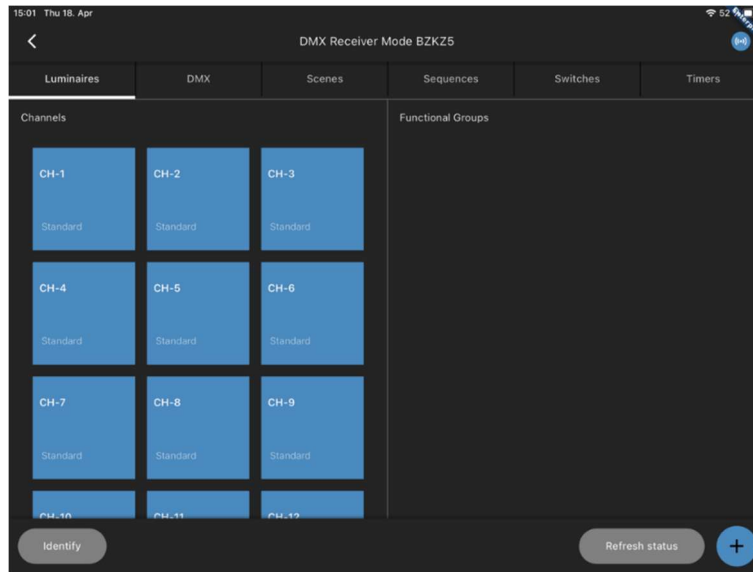

Figure 96: View of the configurable channels

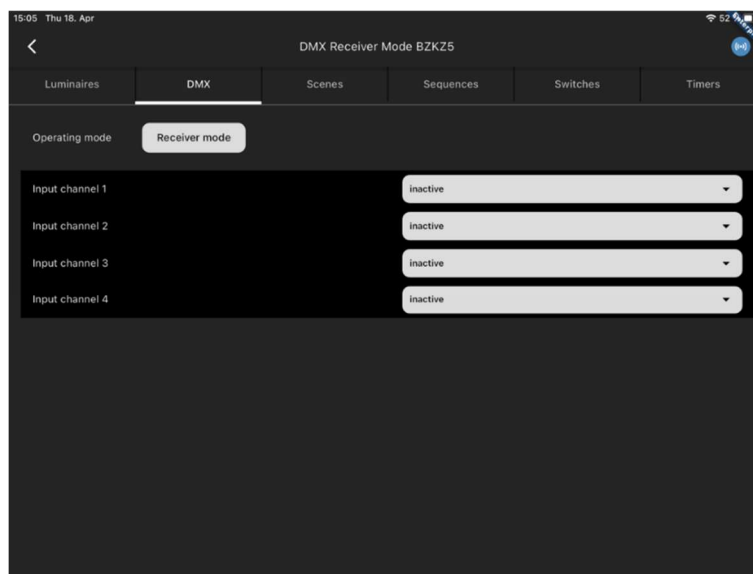

Figure 97: Menu for assigning the channels

Please select the tab “DMX” to access the input channels. In this view, the channels must be assigned according to the channels used by the DMX controller.

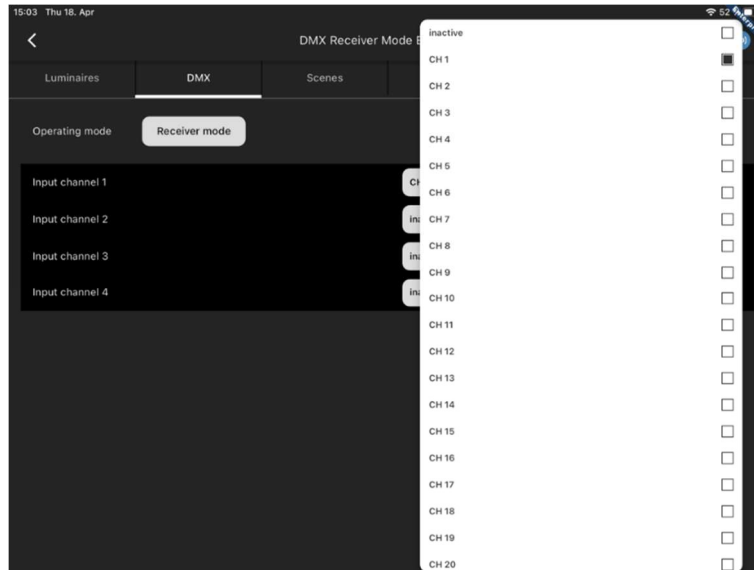

Figure 98: Assignment of channels

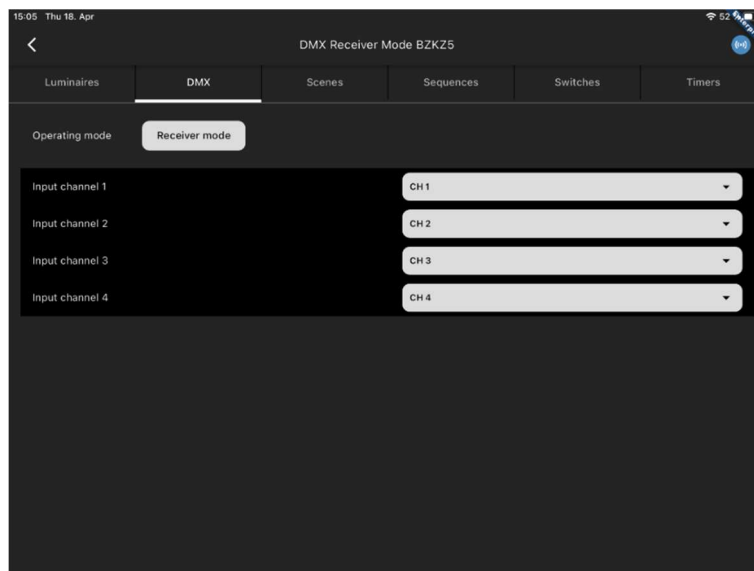

Figure 99: Overview of the assigned channels

21.2 MASTER MODE

This mode is used when the device is connected to a DMX spotlight. After scanning the Node, please select the “Master Mode” and press the button “Continue”.

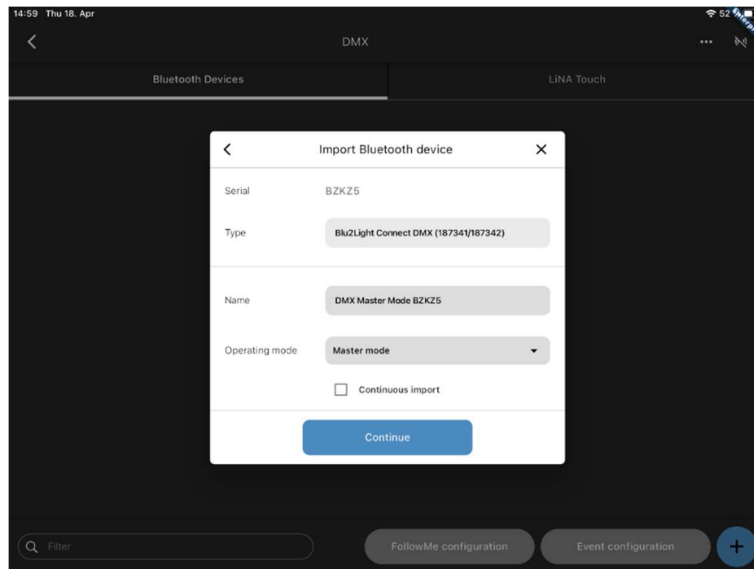

Figure 100: Master mode

By printing the button for the commissioned device, you will come to the following overview. There are 32 assignable channels available.

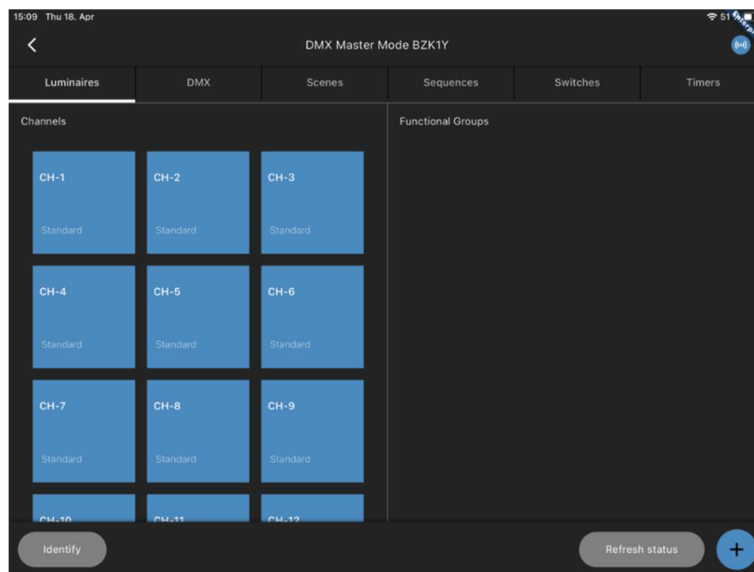

Figure 101: View of the configurable channels

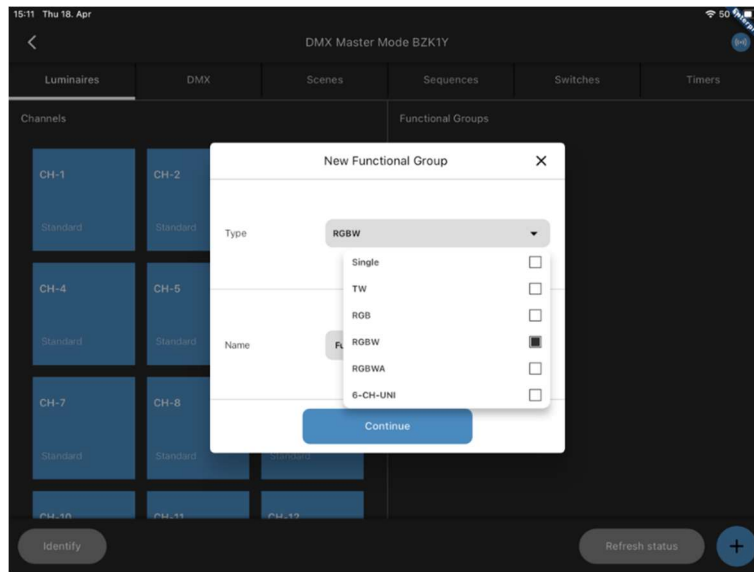

Figure 102: Creating a functional group

You cannot perform an express setup. You must therefore create a function group yourself! Here you must select how many channels your spotlight has. In this case, it is RGBW.

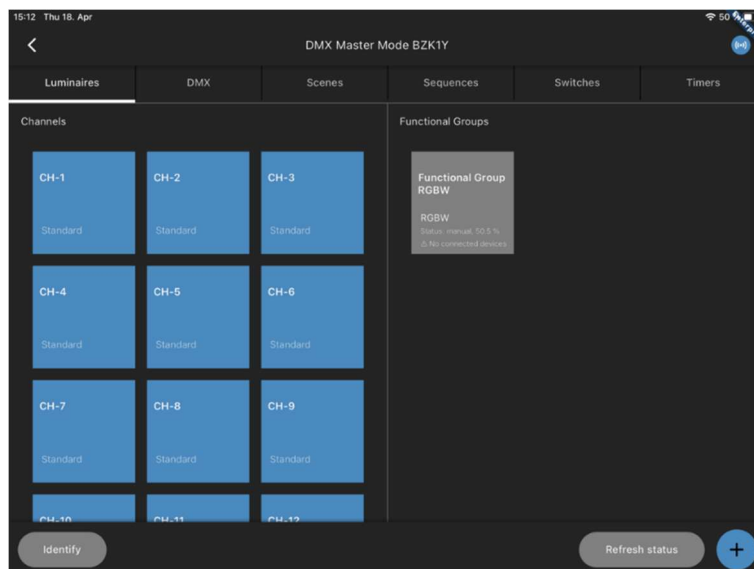

Figure 103: View with created functional group

Pressing the tile of the just created Functional Group takes you to the next step where you must connect every channel of the device (R, G, B, W) to every channel of the Functional Group (also applicable for other systems).

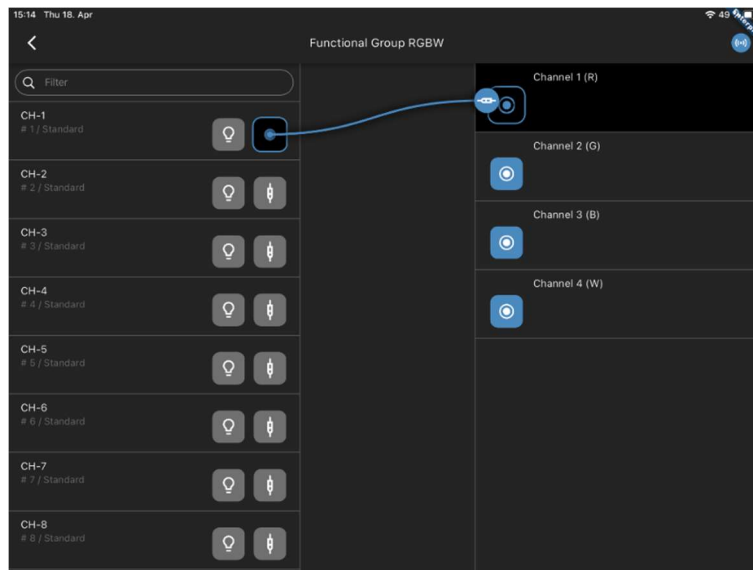

Figure 104: Assigning channels

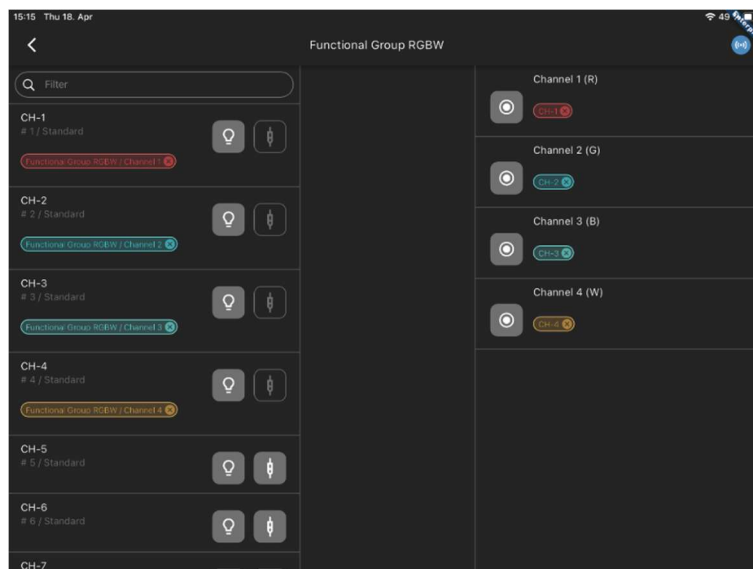

Figure 105: View of the linked channels

Now we configure our scenes as we did for a simple configuration (Figure 10-12). In this case you have the option to either use the channel overview or change the type of scene and use RGBW directly, this could make the selection of colors easier (see Figure 50).

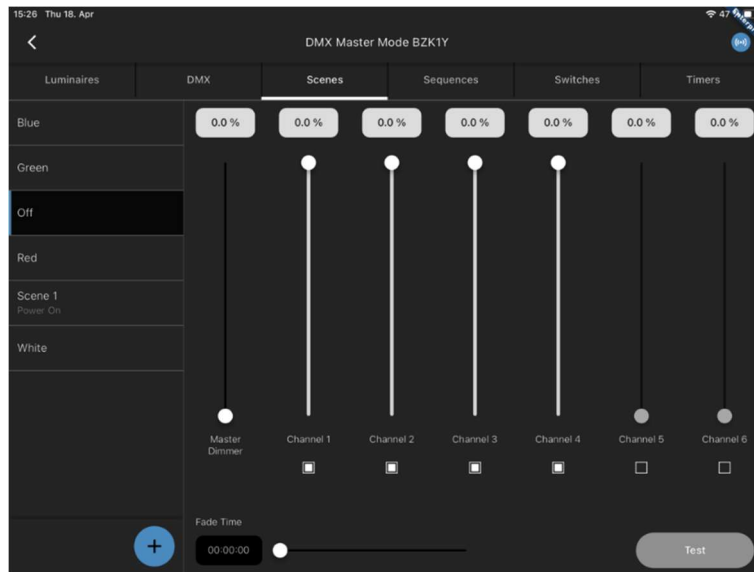

Figure 106: View of scenes created

Once you have configured all the desired scenes, go back to Figure 14 to create a user interface for the LiNA Touch app.

21.3 USING RECEIVER AND MASTER MODE IN COMBINATION

This combination is used when you want to control a spotlight via DMX controller. Please repeat the steps of configuration for Receiver and Master Mode (Figures 95 – 106).

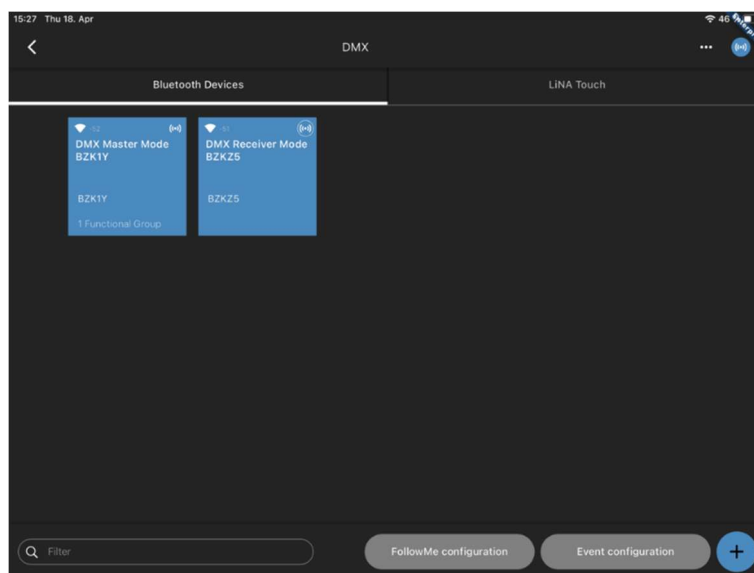

Figure 107: Combination of Receiver and Master

Please open the Event configuration and assign the Push button inputs 1 to 4 of the DMX device in Receiver Mode to functional group of DMX device in Master Mode.

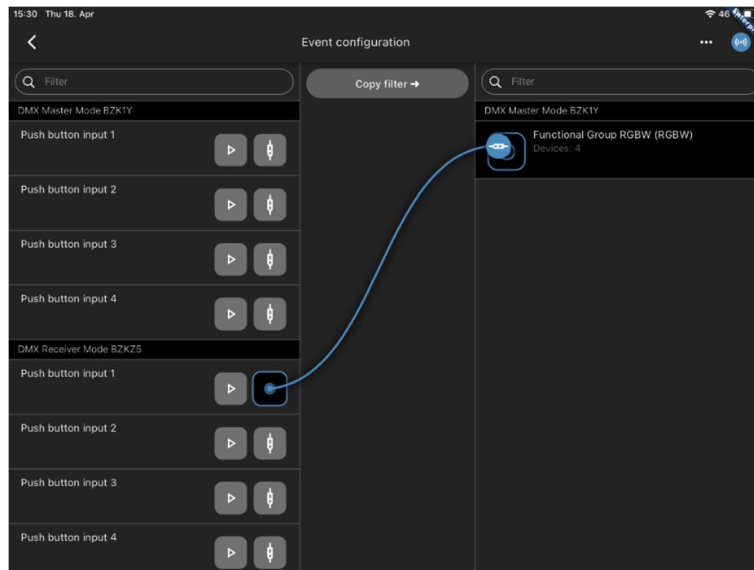

Figure 108: Assigning the button inputs

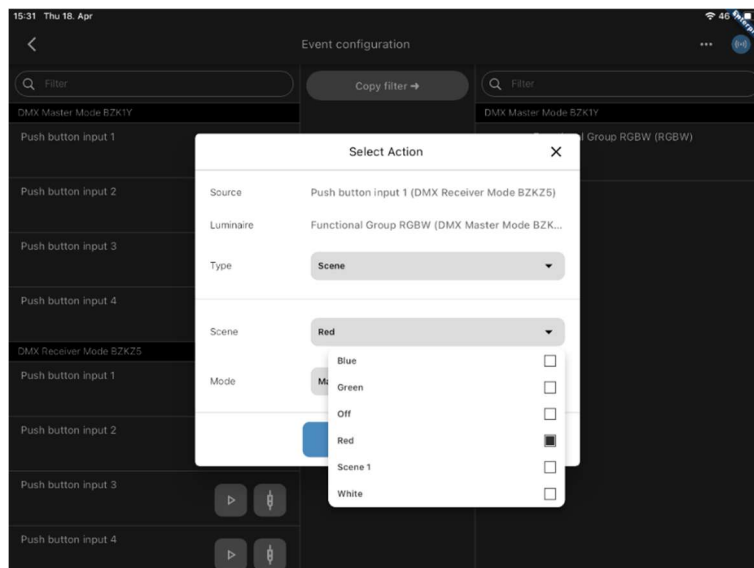

Figure 109: Linking the button inputs with the desired actions

Select the type of action and the desired scene. See the overview mentioned in figure 96.

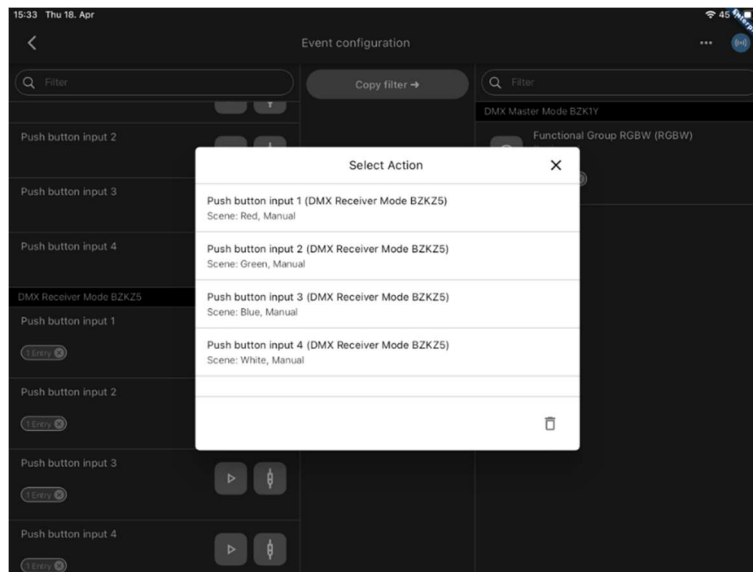

Figure 110: Overview of the links created

After completing the event configuration, you can control the connected DMX spotlight via the DMX control device. The control signals are transmitted from the DMX controller via the DMX device in receiver mode to the DMX device in master mode using a Bluetooth connection.

21.4 MASTER FOLLOWER MODE

The Master Follower Mode allows the DMX light control commands to be passed on as dimming levels. After scanning the Node, please select the "Master Follower Mode" and press the button "Continue".

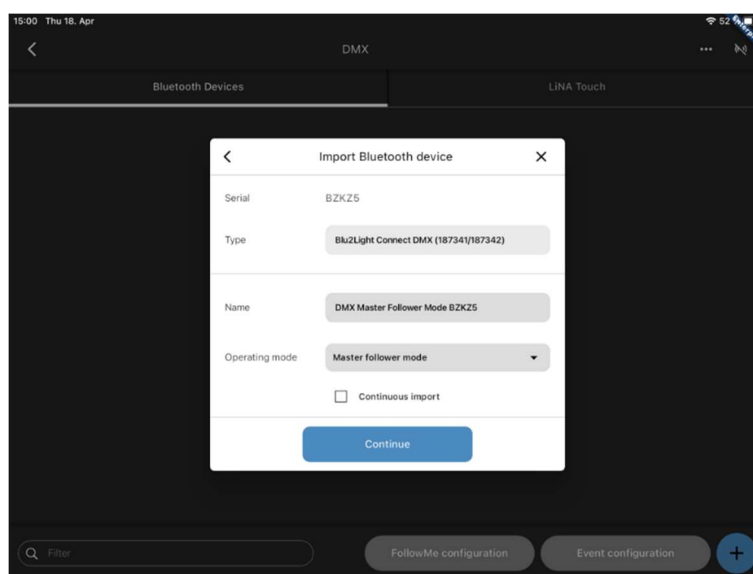

Figure 111: Master Follower mode

You cannot perform an express setup. You must therefore create a functional group by yourself! Here you must select how many channels your spotlight has. In this case, it is RGBW (Figure 102 - 105).

After that you can configure the scenes as we did for a simple configuration (Figure 10-12). In this case you have the option to either use the channel overview or change the type of scene and use RGBW directly, this could make the selection of colors easier (see Figure 50).

The second DMX Node must be configured as Master (Figure 100). Please create a functional group. In this case, it is RGBW (Figure 102 - 105).

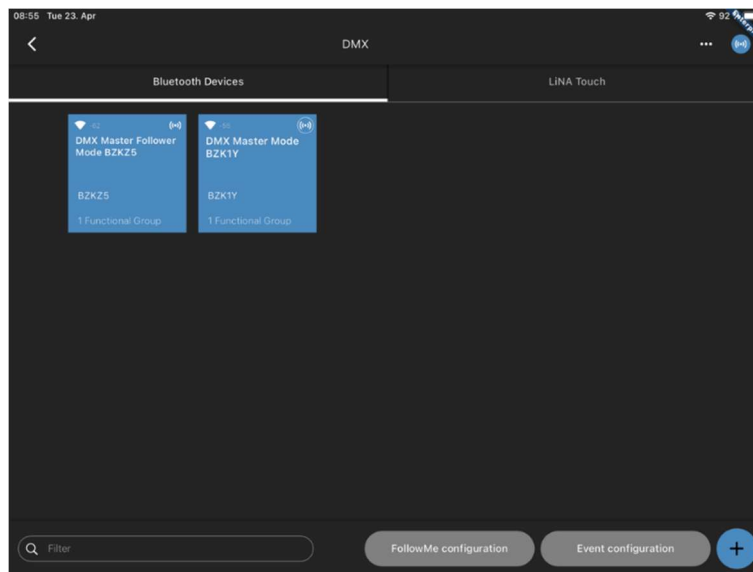

Figure 112: Combination of Master Follower and Master

Please open the FollowMe configuration.

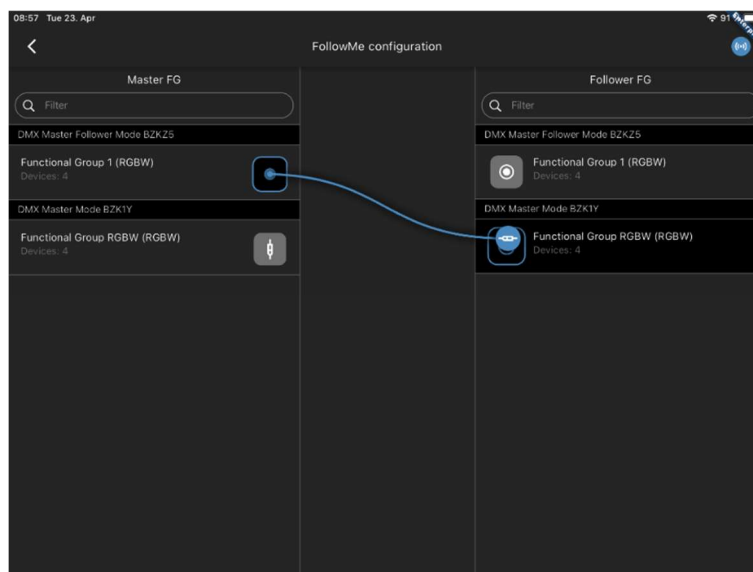

Figure 113: Linking the functional groups

Assign the Functional Group of DMX Master Follower to the Functional Group of DMX Master.

After completing the event configuration, you can control the connected DMX spotlight via the DMX control device. The control signals are transmitted from the DMX controller via the DMX device in Master Follower Mode to the DMX device in Master Mode using a Bluetooth connection.

Switching on the channels on the DMX controller follows the position as dimming level. The mixing of colors is possible.

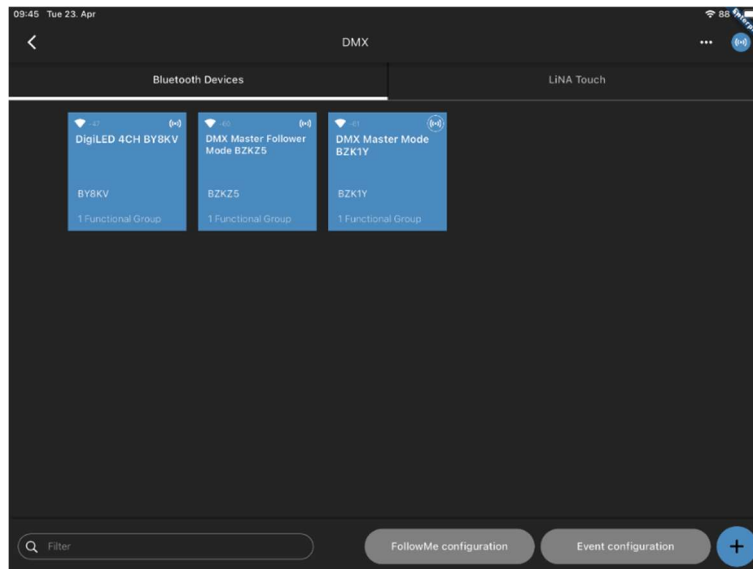

Figure 114: Combination of DMX device with a DigiLED

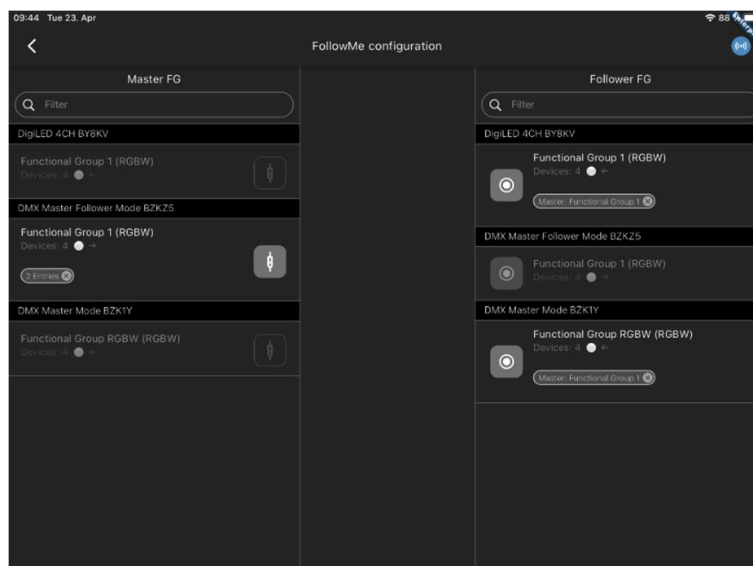

Figure 115: Linking the functional groups

Instead of a second DMX device in master mode, a DigiLED 4CH can also be integrated into the system. The linking is identical (Figure 115). The DigiLED 4CH can also be added to a system consisting of 2 DMX devices (Figure 114).

22 AUTOMATIC ADDRESSING AFTER REPLACING A DALI DRIVER

Any person tasked with system setup, commissioning, operation, maintenance, and repair must be:

- suitably qualified and
- closely observe the provisions of this operating manual.

Please remember to disconnect the power supply before replacing a luminaire or control gear.

After a restart, the following checks are performed:

- Are all nodes registered?
- Are the DALI drivers assigned to all Functional Groups so that they remain available after commissioning?
- Are there any (new) unaddressed¹ DALI drivers?
- Are any previously addressed DALI drivers missing?

Once all points have been checked, the replaced control gear can be integrated during startup.

Three scenarios are distinguished when DALI drivers without addresses are found:

- Only one Functional Group (FG) → Address the DALI driver and add it to the FG.
- Multiple FGs → Check if exactly one address is missing, address the DALI driver, and add it to the FG.
- Multiple FGs → Check if multiple addresses are missing. If this is the case, a standard reconfiguration (Figure 103) is required to correctly assign DALI drivers.

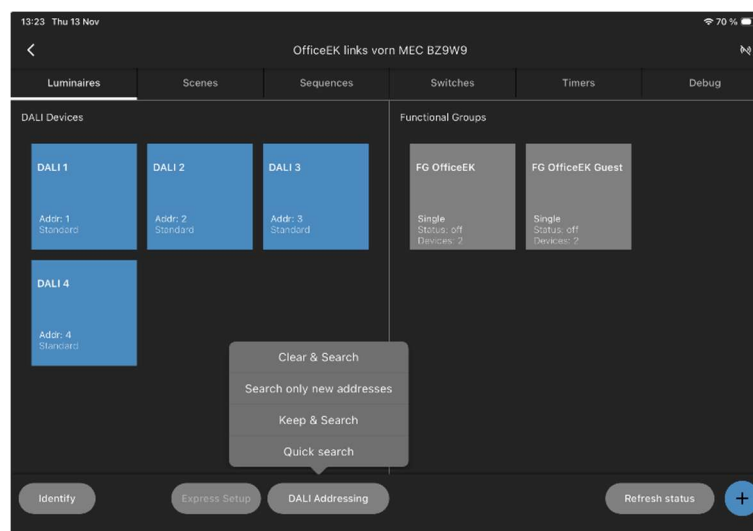

Figure 116: New reconfiguration with **Search only new addresses**

¹ Unaddressed means that the DALI driver must be in its factory default state to be recognized as new.

23 DO'S AND DON'TS

23.1 DO'S

- Always use the latest provided app and firmware
- Read the documentation carefully.
- Always create a backup after configuration
- In buildings in construction, make sure you have a proper and uninterrupted mains supply.
- Steps to configure a system:
 1. Plan.
 2. Document the needed functions.
 3. Scan all QR codes.
 4. Make firmware update.
 5. Create all FGs.
 6. Assign channels to FGs.
 7. Configure power on values.
 8. Connect functions.
 9. Make backup.
 10. Import backup to Server.
- Set up light regulation reference with no (ideal) or minimal external light.
- If you have a technical request, include:
 1. Backup file.
 2. Exported network overview.
 3. Description of the system.
 4. Description of the issue as detailed as possible.
- Use "Follow Me" function wherever possible.
- Always delete a system if it is transferred via backup to another tablet.
- Make a DALI bus power calculation for every DALI bus.
- Place nodes with GPS receivers with open view to the sky.

- Blu2Light is designed to be always ON. To turn OFF the light, create a scene with luminance 0 %.

23.2 DON'TS

- Do not configure all color values to zero for a scene.
- Do not add functional groups to a light regulation on a node that has no own FG and no physical driver connected.
- Do not use long RTA (return to auto) times. We recommend max. up to 2 minutes.
- Do not locate two or more light sensors feeding each a light regulation to close together. If they see the light from a different area this will cause unstable regulation when the other group changes their level.
- Do not change the room setup below the sensor when light regulation is active without reconfiguring the reference value (or expect changes in the reached target level).
- Never turn off the power during a firmware update.
- Never turn off the power directly after configuration changes. **Wait at least 1 minute.**
- Do not use any unknown power supply.
- Don't use weak radio connection between two nodes.
- Never connect too much load on the DALI line.
- Don't Save nodes. Having too less nodes in a system decreases radio stability and reduces the possibility to configure the system for changed behaviors.
- Never use two tablets for configuration in parallel or alternating on one system.
- Using the LiNA Connect App on a finished configuration which already has a LiNA Touch interface is not recommended and can cause malfunctioning of the Touch system while programming on the Connect App in parallel.
- Do not Connect two (or more) Blu2Light controllers on one DALI line (therefore we have the Power Splitter, 187280).

23.3 INFORMAL

- Each functional group has its own state.
 - Manual
 - Auto
 - Sequence

The “Auto” state has a sequence of steps, based on the configuration not all of them might be reached.

- Active
 - Passive
 - Basic
 - Off
- Only the auto states “Active” and “Passive” can be used for light regulation.
 - Movement only reacts in state “Auto”.
 - A sequence can end with a scene call either in active, manual mode or trigger another sequence.

23.3.1 DESCRIPTION OF SYMBOLS

The following graphic shows the symbols that can appear in a created system:

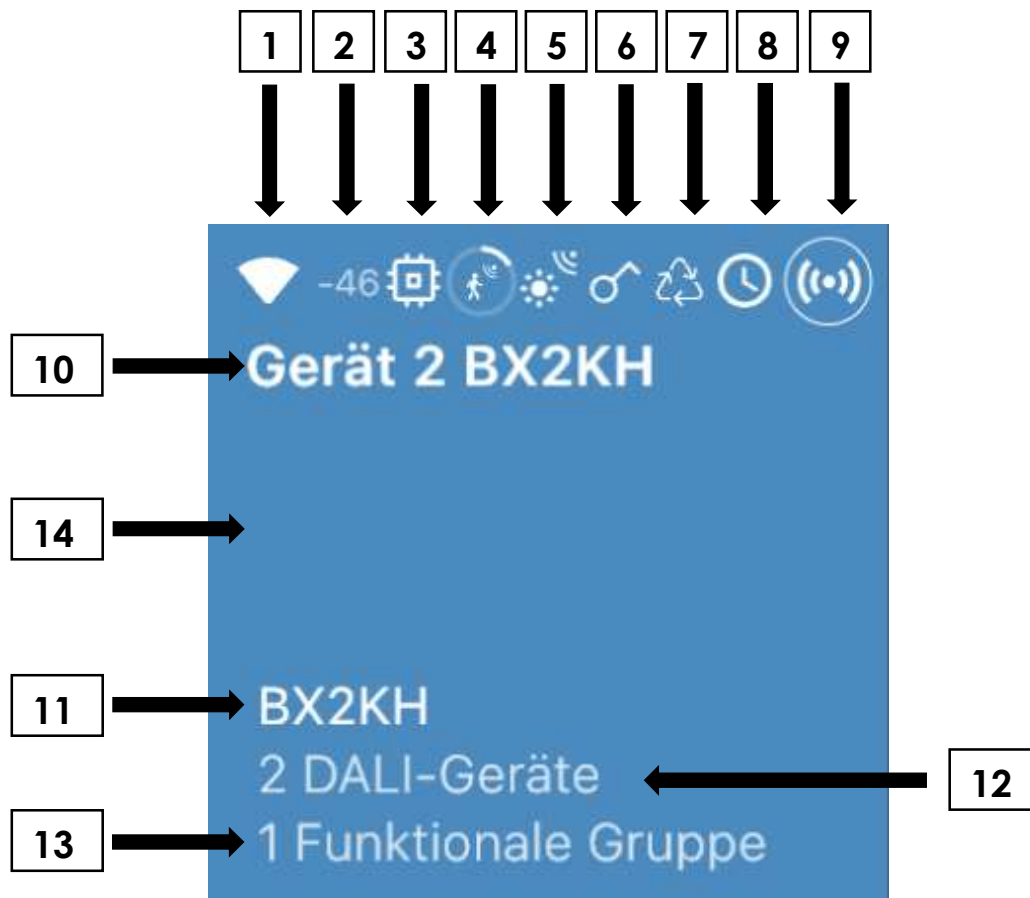

Number	Description
1	The Blu2Light device is directly reachable from the LiNA Connect.
2	Reception level at the tablet location [dBm].
3	Symbol for old firmware on the Blu2Light device. A firmware update is necessary.
4	Motion has been detected within the last 7 seconds (only active if the motion sensor has been activated in the menu)
5	Light regulation on the Blu2Light device is active.
6	An EnOcean-Switch has been added to Blu2Light device.
7	A sequence has been created on the Blu2Light device.
8	A timer has been created on the Blu2Light device.
9	LiNA Connect uses this node as an entry to the Mesh.
10	User defined device name for the Blu2Light device.
11	Blu2Light serial number.
12	Amount of found DALI devices.
13	The number of functional groups on the Blu2Light device.
14	User defined color of the tile. 9 colors can be selected. A black tile indicates that the node is not available or offline. If the selected color is shown, the Blu2Light device is available and in range.

The following graphic shows other symbols that can appear in a created system:

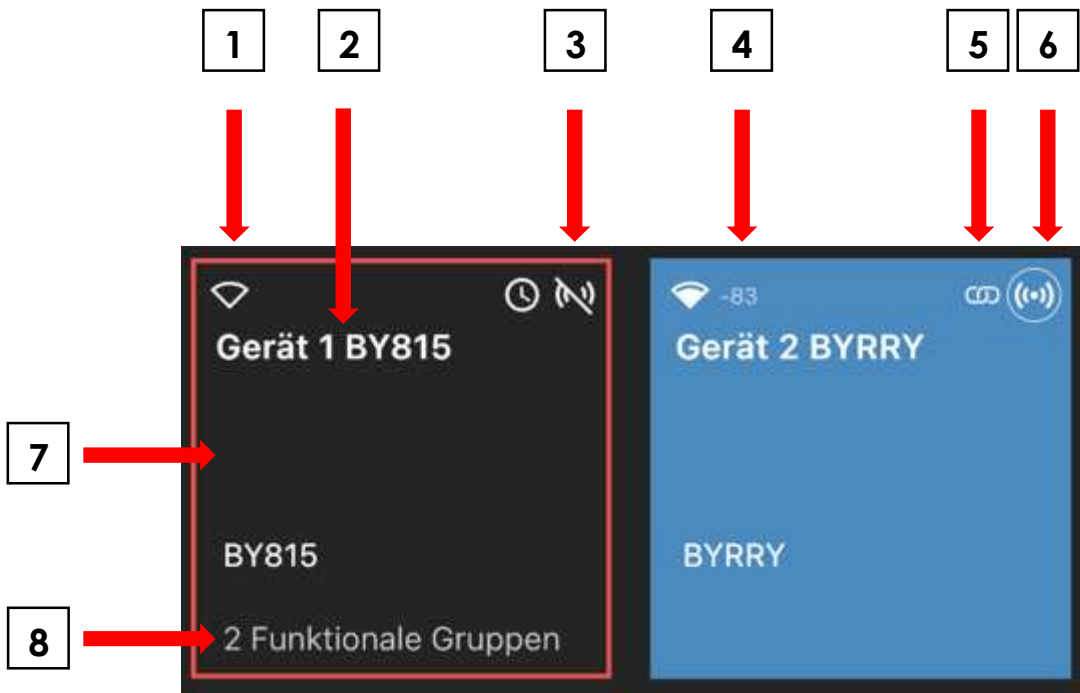

Number	Description
1	The Blu2Light device is not in range - no RSSI value (Received Signal Strength Indicator) available.
2	User-defined name for the Blu2Light device with serial number.
3	The Blu2Light device is out of range.
4	RSSI level available - sufficient quality.
5	The Blu2Light device (gateway) is a network bridge.
6	LiNA Connect is directly connected to this Blu2Light device.
7	The Blu2Light device is offline or cannot be reached within the mesh (tile = black). The Blu2Light device is available = tile appears in the selected color.
8	2 functional groups have been set up on the device.