

iPC

INTELLIGENT POLE CONTROLLER (BUILT-IN)

- 1 Switching Output (Ref. No.: 186234)
- 2 Switching Outputs (Ref. No.: 186649)



Valid from 7 December 2017

Developed for use in street lighting and lighting in the vicinity of buildings, the iPC operates with a standardised power line for communication purposes and enables control of electronic ballasts fitted with a 1–10 V/PWM and DALI interface. Individually programmable and updateable, the controller provides all the functions of a modern light management system and thus ensures a high degree of investment protection. If the controller is temporarily operated in stand-alone mode or if the network is temporarily down due to maintenance work, the basic function parameters of the light management system will be retained for control purposes and with that will yield approximately the same energy saving without energy-consumption values being lost.

Further Advantages

- Standby consumption: < 1.0 W
- Interoperable luminaire controller in acc. with the OLC Lonmark® profile
- Power line communication using a C/B frequency band
- Stand-alone mode, repeating- and iMCU emulation mode
- 10 dimming levels with individual dimming sequences
- Luminaires can be switched off when connected to a switched lighting cable
- Intuitive software-based configuration
- Burning in high-pressure discharge lamps following lamp exchange
- Lighting can be switched on with a delay and switched off earlier with individual dimming sequences
- Compensation of reduction in luminous flux with freely definable values for lamp service life as well as start and end levels
- Adjustable control input to suit various tasks
- Up to 10 time-dependent, synchronisable dimming levels with individual dimming sequences can be set via the control line and the control input
- Connection of various sensors such as motion sensors, key switches and light sensors
- Optionally available with an audio frequency ripple control receiver to enable migration of existing systems
- 5 years warranty

Typical applications

- Street lighting and lighting in the vicinity of buildings
- Car parks, bus stops and railway stations
- Company premises, warehouses
- Sports facilities

iPC Light Controller

Technical Details

Electronic Light Controller	186234	186649
Type	iPC	iPC 2Relay
Input voltage	200 V AC – 250 V AC	200 V AC – 250 V AC
Mains frequency	50 / 60 Hz (+1 % / -2 %)	50 / 60 Hz (+1 % / -2 %)
Power consumption	< 1.0 W	< 1.0 W
Communication	Via the power supply line (power line) in acc. with CENELEC 50065-1	Via the power supply line (power line) in acc. with CENELEC 50065-1
C Band	Primary band 125 – 140 kHz	Primary band 125 – 140 kHz
B Band	Secondary band 95 – 125 kHz	Secondary band 95 – 125 kHz
Data transfer (USA)	ANSI CEA 709.1, ANSI CEA 709.2	ANSI CEA 709.1, ANSI CEA 709.2
Data transfer (Europe)	EN 14908-1, EN 14908-2	EN 14908-1, EN 14908-2
Optional plug-in	Audio frequency ripple control receiver	Audio frequency ripple control receiver
Filter frequencies	100 Hz ... 1.7 kHz	100 Hz ... 1.7 kHz
Protocols	On request	On request
Bit patterns	On request	On request
Galvanic isolation	No electrical isolation from input to output (as soon as the electronic ballast is connected to the iPC, the control input ceases to be galvanically isolated)	No electrical isolation from input to output (as soon as the electronic ballast is connected to the iPC, the control input ceases to be galvanically isolated)
Switching current	4 A, $\lambda = 0.8$	4 A, $\lambda = 0.8$ in total
Switching cycles	50,000 switching operations per function (I, λ)	50,000 switching operations per function (I, λ)
Programmable	Yes	Yes
Configurable parameters	Yes	Yes
Switching output luminaire	1 x for connecting several luminaires	2 x for connecting several luminaires
Control output power-reduction relay	1 x to address an electronic power reduction relay (control current ≤ 10 mA, not protected against short-circuiting)	1 x to address an electronic power reduction relay (control current ≤ 10 mA, not protected against short-circuiting)
Control output EB	1 x DALI or 1–10 V: short-circuit-proof, suitable for respective ballasts, DALI bus master interface for max. 4 ballasts	1 x DALI or 1–10 V: short-circuit-proof, suitable for respective ballasts, DALI bus master interface for max. 4 ballasts
Connection	1.5 mm ² , 900 mm	1.5 mm ² , 900 mm
Conductor type of the connection terminals	Stranded with ferrule bare end of core	Stranded with ferrule bare end of core
Firmware update / Parameter config.	Via power line	Via power line
Control and monitoring parameters	Switch on and off, reduction	Switch on and off, reduction
Capture of measured data	Voltage, current, power factor, output, energy, temperature, lighting hours with an accuracy of better than 1%	Voltage, current, power factor, output, energy, temperature, lighting hours with an accuracy of better than 1%
Software interface	Interoperable in acc. with the Lonmark® OLC profile, use of network variables and configuration parameters, repeatable	Interoperable in acc. with the Lonmark® OLC profile, use of network variables and configuration parameters, repeatable
Operating temperature range t_c	-25 to +80 °C	-25 to +80 °C
Storage temperature range	-25 to +85 °C	-25 to +85 °C
Humidity	90% non-condensing	90% non-condensing
Surge voltage protection	4 kV / 1.2 / 50 in acc. with DIN EN 61037	4 kV / 1.2 / 50 in acc. with DIN EN 61037
Degree of protection	IP65	IP65
Casing material	PC	PC
Dimensions (W x H x D)	66.4 x 249.9 x 54 mm	66.4 x 249.9 x 54 mm
Weight	400 g	400 g
Country of origin	Made in Germany	Made in Germany

The values contained in this data sheet can change due to technical innovations. Any such changes will be made without separate notification. Please find further detailed information at www.vossloh-schwabe.com.

iPC Light Controller

Dimensions (mm)

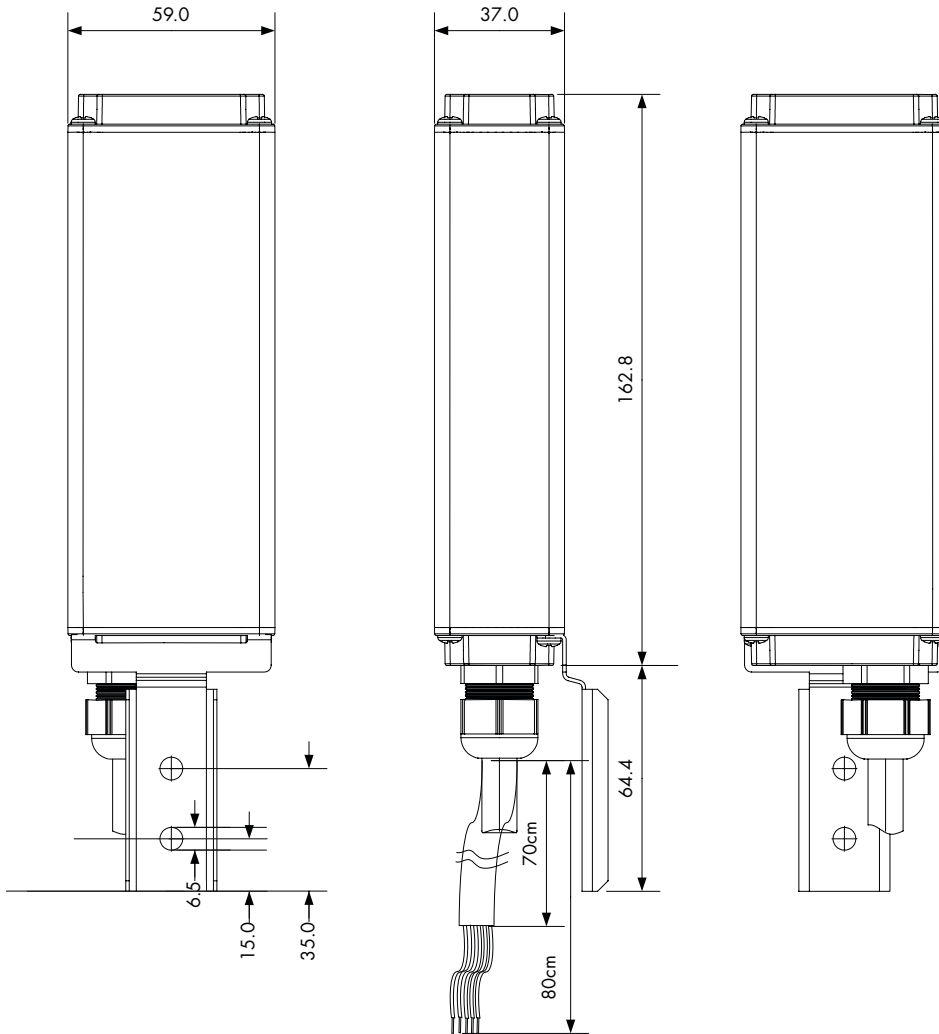

The 1–10 V/PWM/DALI output of the built-in pole controller enables control of 4 (max.) electronic ballasts to enable effective control of luminaire groups or, for instance, LEDs for R, G, B and W. The digital control input ceases to be electrically isolated as soon as an electronic ballast is connected to the controller. The configurable parameters of the applications as well as optional firmware updates ensure a high degree of investment protection. Also, OEM- and customer-specific versions can be protected against unauthorised distribution with a special software key. Please contact your VS representative for more information on this function. As soon as an electronic ballast is connected to the iPC, the control input ceases to be electrically isolated.

iPC Light Controller

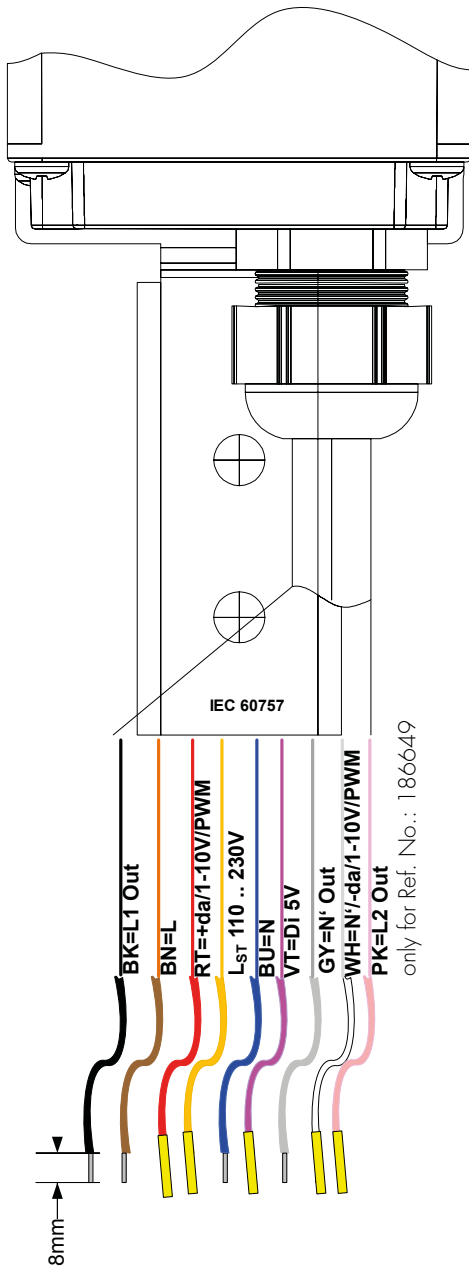

Cable Assignment Supply Side					
According to IEC 60757					
Colour	IEC 60757		Configuration	Feature	
				Product 186234 Product 186649	
Abbreviation					
<input type="checkbox"/> Black	SW	sw	BK	L1 Out	
<input type="checkbox"/> Brown	BR	br	BN	L	
<input type="checkbox"/> Red	RT	rt	RD	+da / 1-10V	Shrinking
<input type="checkbox"/> Orange	OR	or	OR	L _{ST} 110 .. 230V	Shrinking
<input type="checkbox"/> Blue	BL	bl	BU	N	
<input type="checkbox"/> Violett	VI	vi	VT	Di 5V	Shrinking
<input type="checkbox"/> Grey	GR	gr	GY	N' Out	
<input type="checkbox"/> White	WS	ws	WH	N' /-da/1-10V	Shrinking
<input type="checkbox"/> Pink	RS	rs	PK	L2 Out	Product 186649
<input type="checkbox"/> IEC = International Electrotechnical Commission					
<input type="checkbox"/> Cable 10 x 1 mm ² , cable length ca 100 cm, Ölflex-sheathed cable Classic 100. PCB side solder connection/External ferrule connection					
<input type="checkbox"/> In case of unnecessary remaining and not connected wires, wires have to be cut off and electrically isolated					

iPC Light Controller

Circuit Diagram

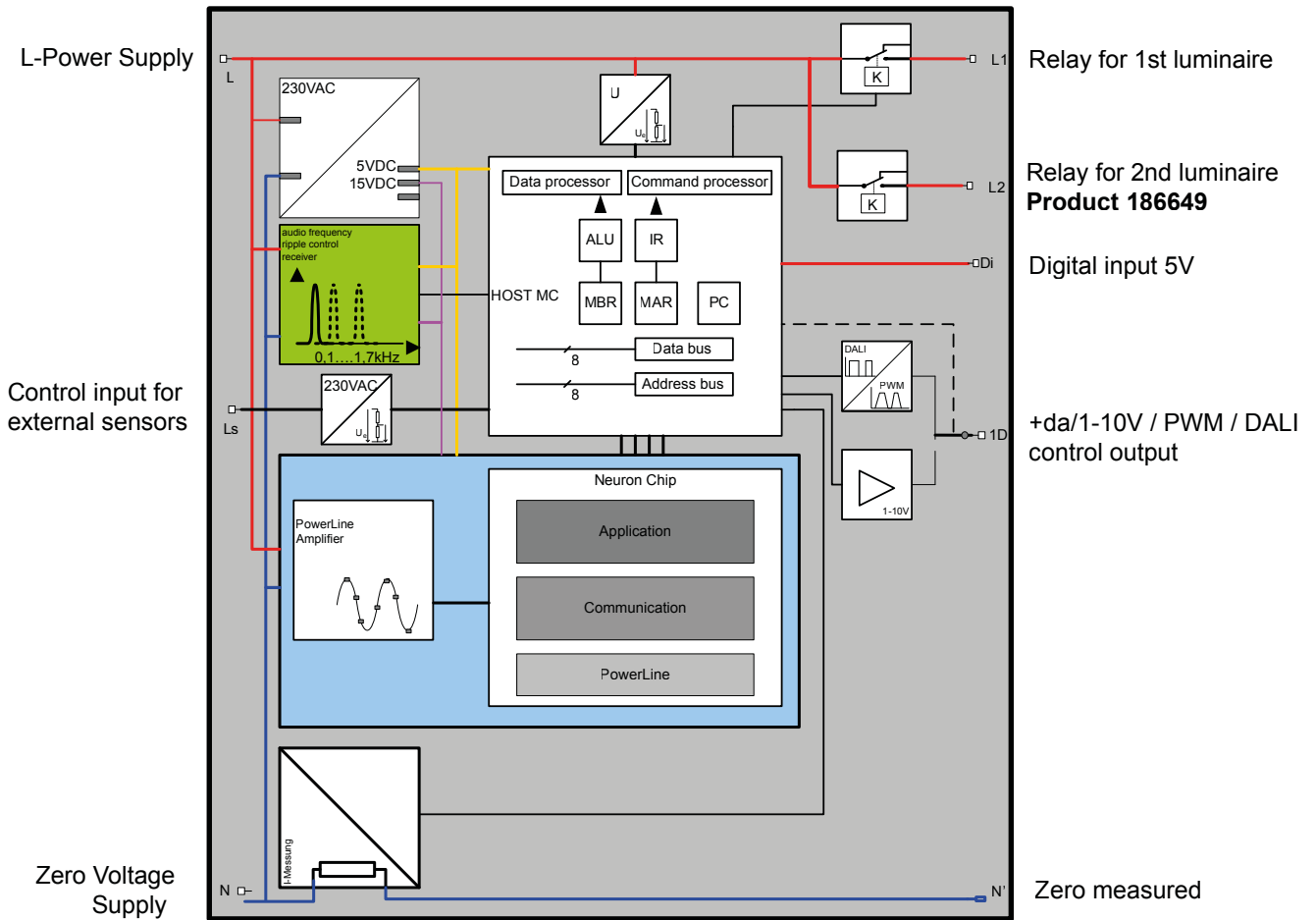

iPC Light Controller

Functions

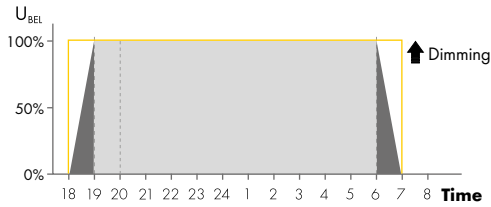

DOO (Dimmed ON/OFF)

The lighting system can be programmed to ensure the lighting level of luminaires slowly increases to the desired brightness upon being switched on and to dim down within a certain timeframe before switching off. The brightness of modern luminaires based on LED technology can also be increased slowly up to a defined lighting level immediately after they have been switched on. This function enables a brightness-dimming/-increasing sequence of 36 minutes (max.) to be set.

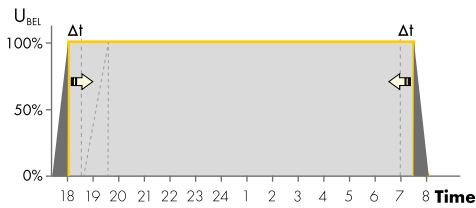

DPC (Delayed Switching for Pedestrian Crossing)

The lighting system can be programmed to switch on after a certain delay and switch off earlier in areas just outside of pedestrian crossing zones. For instance, street lighting is typically to be activated at 40 lux within pedestrian crossing zones, but at a lower lux level in areas outside of this zone. If the cabling infrastructure needed to set up such a system is missing, the iMCU controller can emulate a similar effect thanks to its ability to "learn". Pedestrian crossing zones can be switched for a longer period, whereas the remaining lighting can be switched independently and/or dimmed after a certain "learning" period.

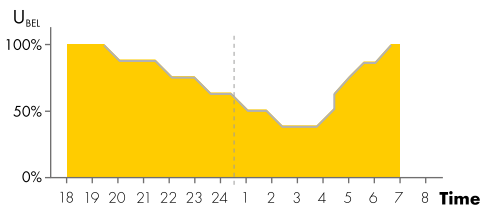

ISD (Intelligent Switching Time Dimming)

Intelligent, timer-controlled periods of dimmed light
A season-specific reference value is derived from the period of time the lighting cable is switched on. In line with this reference value, the controller can manage the lighting system with up to 10 dimming levels and dimming sequences. Accidental (erroneous) configurations that can arise, for instance, during maintenance work, are suppressed by the controller as it ignores short lighting periods of less than 6 hours and long periods of more than 18 hours.

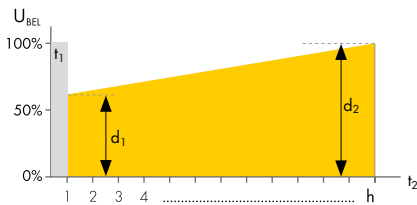

MAFF (Maintenance Factor Function)

Maintenance factor function: reduction of the degree to which the luminous flux decreases over the service life of the light source
Lamps age; mirrors and glass luminaire covers get dirty. This unwanted effect is compensated over the service life of the lamp to ensure a constant luminous flux. The effect can be combated by quantifying the expected decrease in luminous flux over the lamp's service life, which helps to save energy costs. This function can also be used to precisely set the luminaire to suit the lighting task if the lighting level would otherwise be too high as a result of a substitute luminaire.

t₁

Period of time during which a lamp is burned in, i.e. the time during which it must not be dimmed (typically 100 hours).

t₂

Service life of the lamp expressed in x1000 hours.

d₁

Dimming value at the time of commissioning. The set value is shown in %.

d₂

Dimming value at the end of the lamp's service life. The value is shown in %.

L_{ST} (Control input)

Control input with configurable behaviour and effect on the DALI/1–10 V/PWM output and the relay's two-way contact.

The values contained in this data sheet can change due to technical innovations. Any such changes will be made without separate notification. Please find further detailed information at www.vossloh-schwabe.com.

iPC Light Controller

Configuration and Graphic User Interface

If the controller is initially operated without a light management system, the configuration process is undertaken using a programming tool. Despite being a highly complex piece of technology, the controller's intuitive software interface makes it both user-friendly and easy to configure. The GUI enables direct configuration via the power line. If the controller is integrated into a light management system, the same functions are available, but the parameters are configured from a central control point and lighting control is web-based. In this case, time control using the "synthetic" midnight is only used as a redundant application.

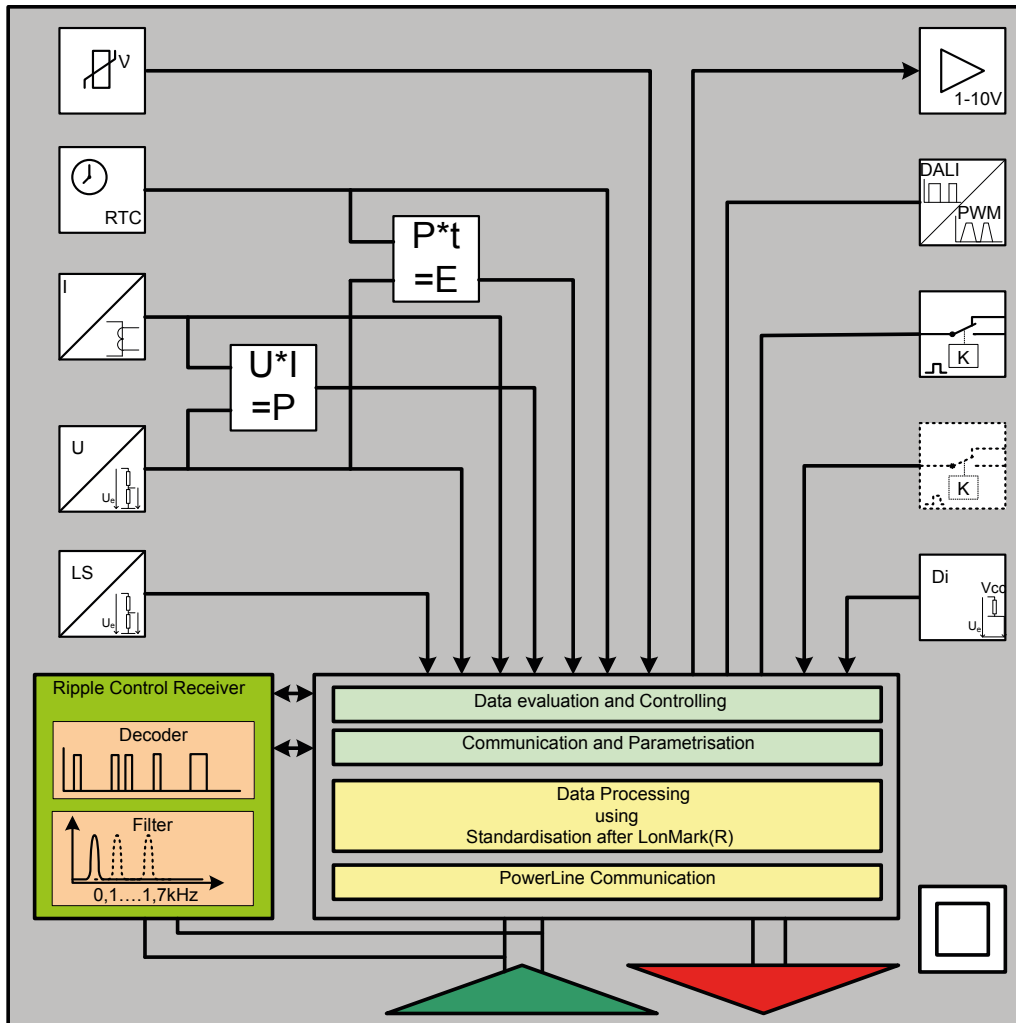

only for Ref. No.: 186649

iPC Light Controller

Lonmark® OLC Profile

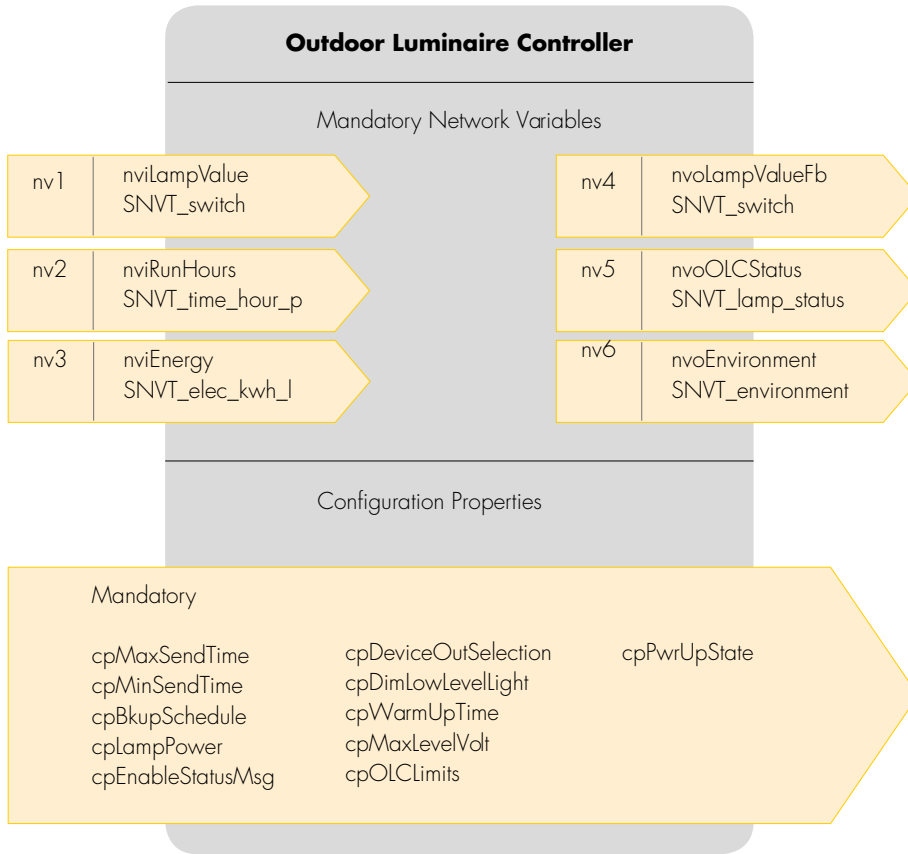

In accordance with the mentioned ANSI and EN specifications, the controller is fitted with an interoperable network interface, which is essential for setting up heterogeneous networks. The definition of the exact data structure for data transfer purposes is fixed in accordance with the Lonmark definition in line with the so-called OLC profile (Outdoor Luminaire Controller). Controllers that are manufactured in line with this standard, even if produced by different manufacturers, can be integrated into a common network.

iPC Light Controller

Connection of electronic ballasts with a 1-10 V/PWM/DALI control input

Apart from being able to address all commonly available ballasts, the controller also makes it possible to completely switch off electronic ballasts if connected to a switched lighting cable. Luminaires operated with 1-10 V electronic ballasts, in particular, acquire an important additional function as a result of being switched off.

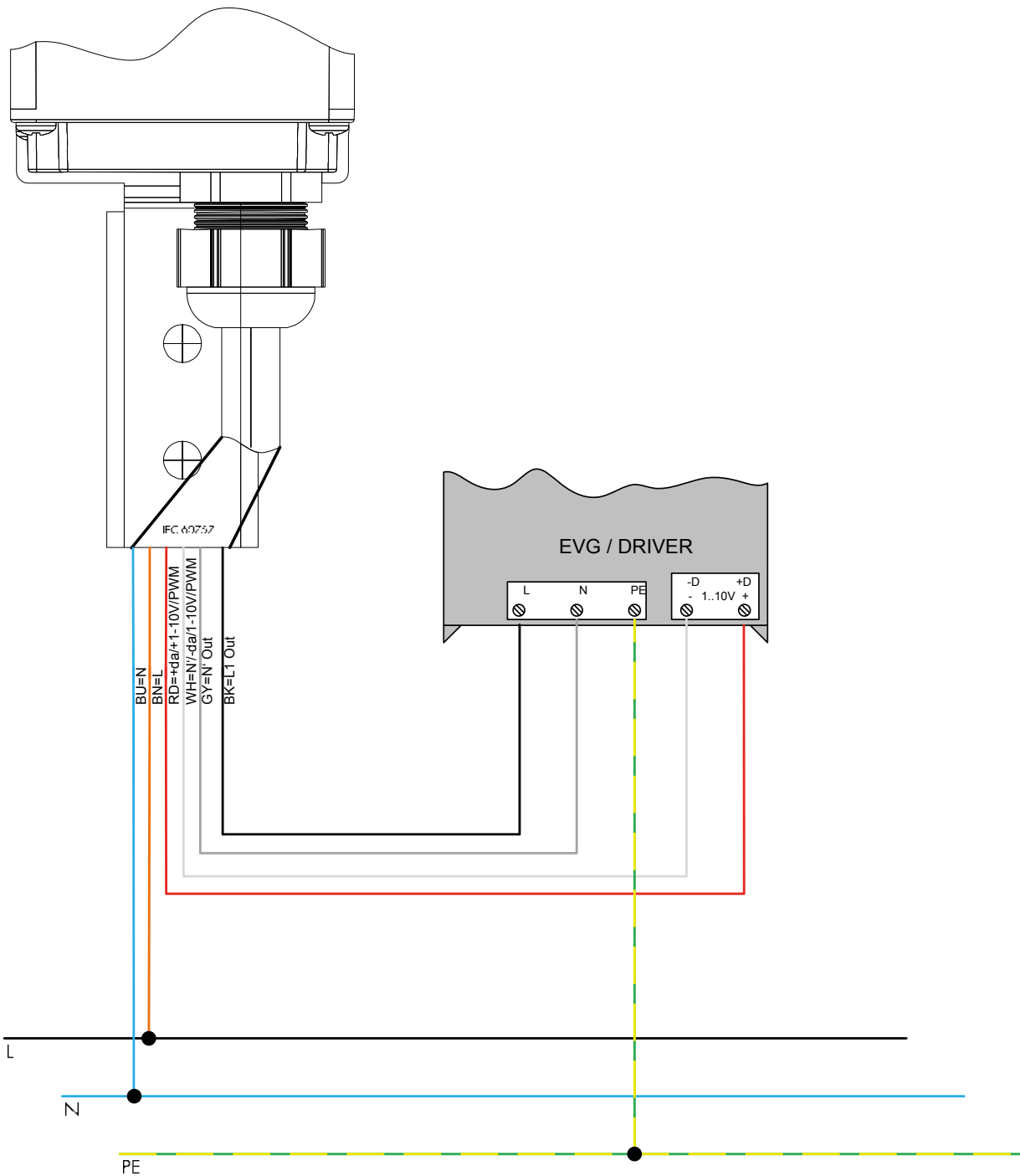

The values contained in this data sheet can change due to technical innovations. Any such changes will be made without separate notification. Please find further detailed information at www.vossloh-schwabe.com.

iPC Light Controller

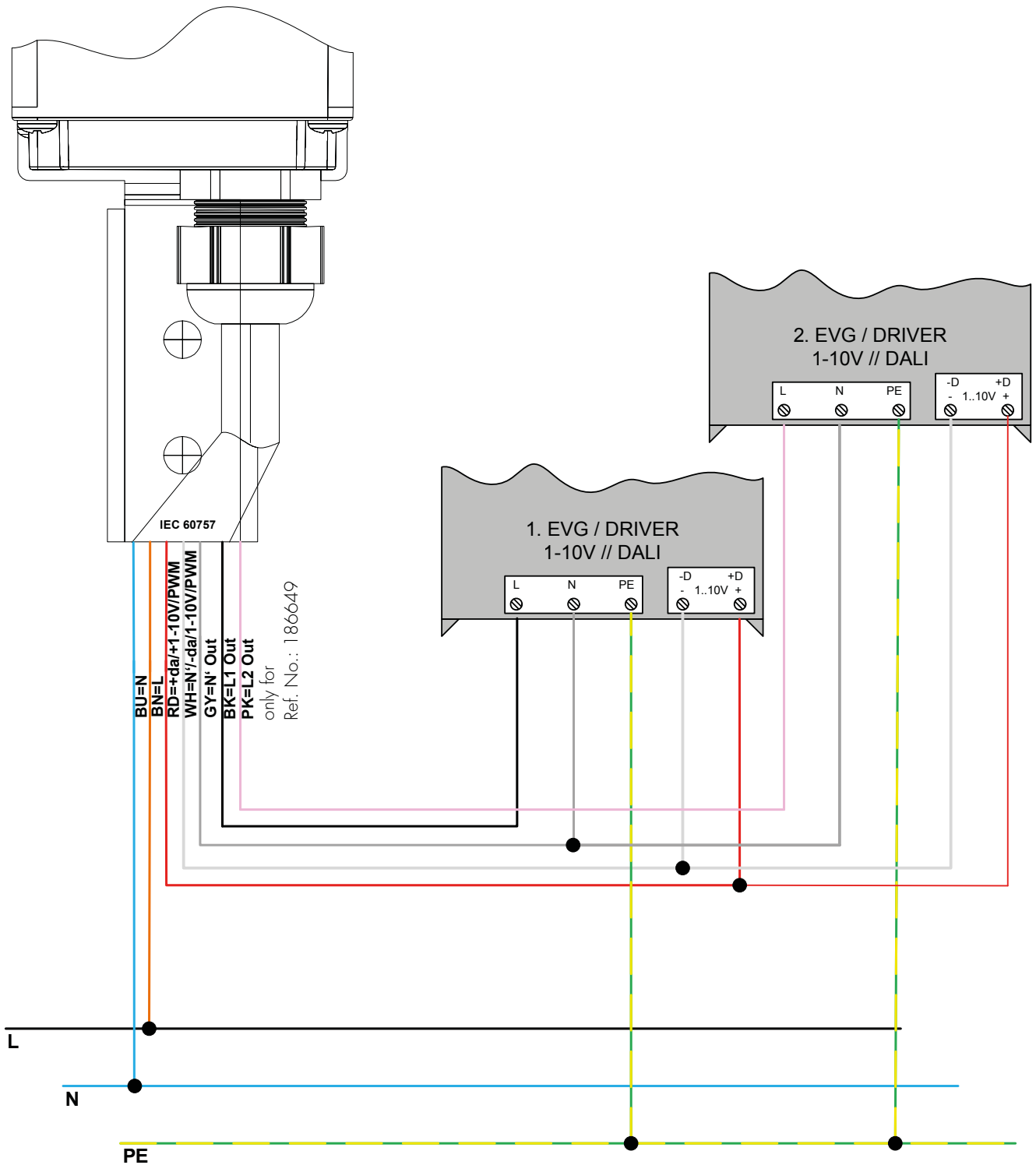

iPC Light Controller

Control using the L_{ST} control input via a motion sensor or control line

The L_{ST} input is designed for 230 V AC. Different functions can be used depending on the given configuration. When using a motion sensor, the lighting period can be defined in the controller. If motion is detected again during this period of time, the lighting period will restart for the specified time.

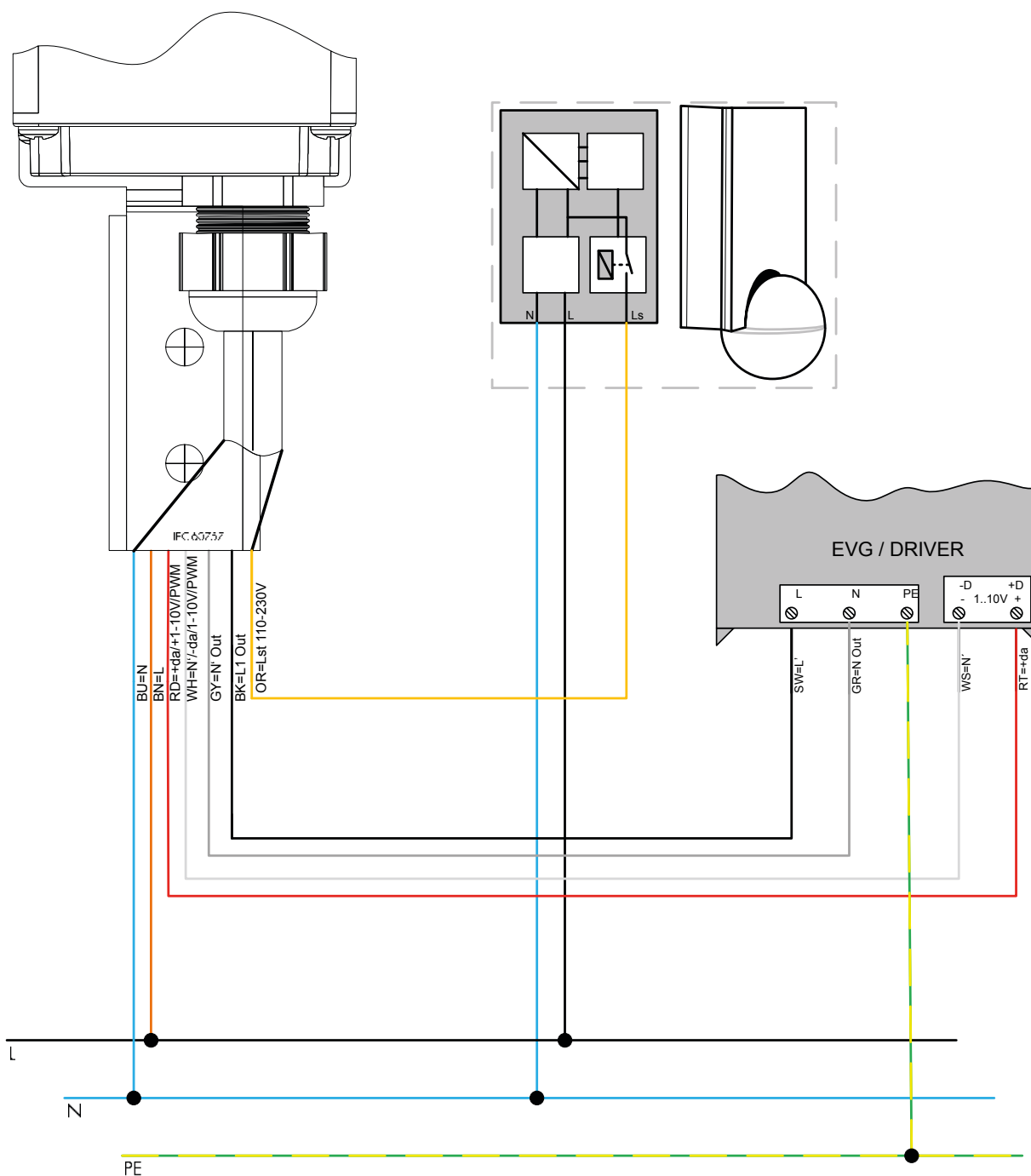

iPC Light Controller

Sales Text

Network-capable, multifunctional, intelligent built-in pole controller featuring power line communication, stand-alone functionality and an optionally available audio frequency ripple control receiver that is suitable for street lighting, lighting in the vicinity of buildings and industrial (high-bay) lighting. The iPC enables control of luminaires operated with standard electromagnetic ballasts, standard electromagnetic ECO ballasts as well as electronic ballasts with a 1–10 V or a DALI interface. The controller permits control of luminaires if connected to a switched lighting or mains cable. All kinds of sensor can be used with the universal control input. Ballasts with a DALI interface are addressed using a broadcast command, which removes the need for commissioning the electronic ballast. The controller is configurable and updateable. Key parameter values such as voltage, current, output, energy and lighting hours are captured for transfer to a central control point for evaluation. When the controller is operated in stand-alone mode, it is possible to set 10 switching times that are derived on the basis of the daily operating period; individual dimming sequences and dimming levels can be set for each of these 10 switching times. The 230 V AC control input permits the superimposed use of up to 10 time-dependent dimming levels and dimming sequences. Furthermore, when used in sensor mode, the holding time for motion sensors can be freely and retriggerably defined. When used in areas outside of pedestrian crossings, this special configuration makes it possible to delay or bring forward the point in time when luminaires are switched off. Time offset, dimming sequences as well as dimming levels can be freely defined.

Text for Invitation to Tender

Powerline-capable controller for integration into luminaires, available with an optional audio frequency ripple control receiver. The iPC enables control of luminaires in street lighting and lighting in the vicinity of buildings that are operated using a switched lighting cable or an unswitched mains cable in combination with a sensor or a control line. Data transfer is undertaken in accordance with the ANSI CEA (709.1, 709.2) and the EN 14908(-1, -2) standards. The controller communicates using the OLC-Lonmark® profile. In line with the LON philosophy and the OLC Lonmark® definition, the controller is equipped with the requisite applications to enable control as well as calculation of data and limit values. Luminaires operated with a magnetic ballast, optionally with a power reduction relay, or with an electronic ballast with a 1–10 V/PWM or DALI control input can be connected and addressed. In accordance with CENELEC and DIN EN 50065-1, bi-directional LON power line communication is effected using the C band (125...140 kHz) for primary communications and the B band (95...125 kHz) for secondary communications. The built-in luminaire controller 186234 features a switched output that makes it possible to turn a luminaire of up to 4 A on/off. The version 1866489 comes with two switching outputs and a maximum capacity of 4A in total. To enable electronic ballasts to be addressed, the controller also features a configurable, short-circuit-proof control output (I_{max} 15 mA) for a DALI or 1–10 V output. Used as a bus master during DALI operation, commands are transmitted to electronic ballasts in broadcast mode. Optionally (configured) individual electronic ballasts can also be addressed via an allocated short address. The controller is suitable for ballasts fitted with a galvanically isolated input, but that lose their basic electrical isolation when connected to the controller.

Electrical specifications: mains voltage 230 V (10%), mains frequency 50 Hz (+1% / -2%), nominal current max. 4 A, power consumption 1 VA (standby) / 6.75 VA (transmission mode), surge voltage protection 4 kV / 1.2 / 50 in acc. with DIN EN 61037, protection class II. Measuring accuracy: voltage U_{eff}, current I_{eff}, output P_{eff}, upwards of 1% in acc. with upper range value, energy kWh better than 1%, temperature, phase shift $\cos \leq 0.02^\circ$. Climatic conditions: operating temperature -25 °C to +80 °C, storage temperature -25 °C to +85 °C. Polycarbonate plastic casing. Dimensions (W/H/D): 93 mm / 58 mm / 30 mm. Weight: 400 g, degree of protection: IP65. Synchronisable real-time clock. Interoperable software interface, use of network variables and configuration parameters in acc. with Lonmark®, control and monitoring parameters: switching on and off, power reduction/dimming, lighting hours, input voltage, current to the ballast/electronic ballast, phase shift $\cos(\phi)$, calculated power uptake and energy consumption. Configuration and monitoring of limit values for voltage, current, capacitor effect (only with magnetic control gear). Optionally extendable current measuring range via externally calibrated current converters in steps of 10 A to 100 A. The decline in luminous flux over the lamp's service life can be compensated. Start and end values as well lamp service life values can be freely configured. For new lamps, the entire superimposed dimming function can be switched off in a lamp- and lighting-hour-dependent manner.

During optional stand-alone operation, the dimming level is automatically calculated and tracked, which enables energy-optimised operation via the lamp's lighting hours as well as by adjusting over-dimensioned luminaires to suit specific lighting tasks. When in operating mode, the controller can be connected to a switched lighting cable or an unswitched network cable in combination with a sensor or a control line. Given typical use when connected to a switched lighting cable, the controller "learns" what time it is by itself based on the periods of time it was switched on during the first three days of operation; the detected time of day is then used to derive the real-life switching times. Up to 10 freely configurable times of day are available for setting the EB's dimming values. The switching status of the relay, the dimming value and the dimming sequence is individually configurable on the basis of the time set in the Parameters section. The 230 V AC control input can be used to influence the internally calculated switching and dimming function. The control input initiates up to 10 timers that exert superimposed control over the sequence of the relay's switching status, the dimming value as well as the dimming sequence. Per timer, the switching status of the relay, dimming value and dimming sequence can be individually configured.

The values contained in this data sheet can change due to technical innovations. Any such changes will be made without separate notification. Please find further detailed information at www.vossloh-schwabe.com.